

## High Current DC Feedthrough Filter 400 Amp

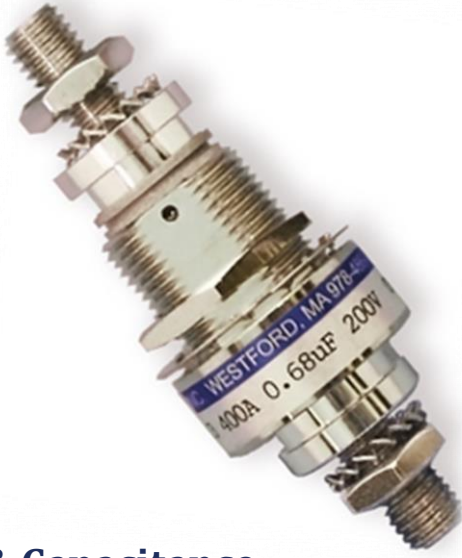

- ✓ Excellent EMI filtering
- ✓ Compact and lightweight
- ✓ "C" Type Filter
- ✓ Bolt-in style
- ✓ High Shock & Vibration
- ✓ CDR and JAN Reliability levels available

### Voltage & Capacitance

400A		Capacitance $\mu\text{F}$																					
		.01	.015	.022	.033	.047	.068	.1	.15	.22	.33	.47	.68	1.0	1.5	2.2	3.3	4.7	6.8	10	15	22	
Rated Voltage	Vdc	100						+					+					+		+		+	
		200						+					+					+		+		+	
		500						+					+					+		+		+	
		1000						+					+										
Rated Voltage	Vac	120	+			+		+															
		250	+				+																

+ Standard Values

### Insertion Loss

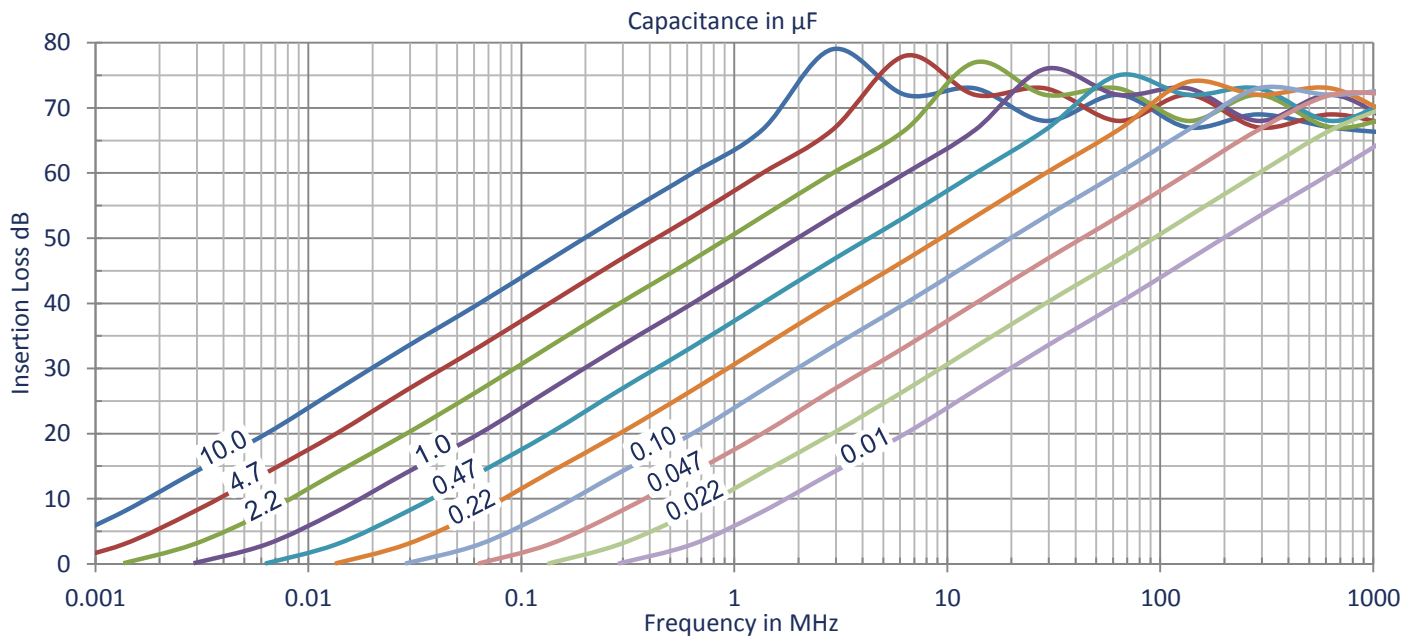

**Specifications (Units to MIL-C-49467, MIL-C-55681, MIL-C-123 or customer SCD available in E-Series)**

Parameter	Value	Description / Specification / Method
Current	400 Amperes	50, 55, 140, 175, 250, & 400 Amps available
Insertion Loss	See Performance Curve on page 1	Per Capacitor Value
RF Current	15A <sub>rms</sub>	
Insulation Resistance	100ΩF (100MΩ Maximum) at 25°C	MIL-STD-202 Method 302
Dielectric Withstand Voltage	250% Rated Voltage (50mA 5s)	MIL-STD-202 Method 301
Dissipation Factor	3% Maximum	MIL-STD-202 Method 306
Voltage Drop	19mV	Wire to Wire
Operating Temp	-55°C to +125°C	40A@125°C to 400A@105°C
Temperature Rise	22.4°C Typical at 400A	
Heat Rise Constant	2.36 to 4.0	C <sub>1</sub> in formula $\Delta T = C_1 \times W^{0.85}$
Storage Temperature	-55°C to +105°C	
Fungus	Non-Nutrient	MIL-HDBK-454A
Corrosion (metal finish)	5% NaCl / 35°C / 48 hrs	MIL-STD-202 Method 101D / Cond B
Humidity	98%RH 25°C-65°C	MIL-STD-202 Method 106E
Shock	30g – 11ms	MIL-STD-202 Method 213B / Cond A
Terminal Strength	Torque: 200 in-lbs (22Nm) Pull: 200lbs (91kg)	MIL-STD-202 Method 211A / Cond A & E
Reliability(MTBF)	500,000 hrs	MIL-HDBK-217F Cond - N2 A(IF) 70°C 50%V

## Mechanical Specifications

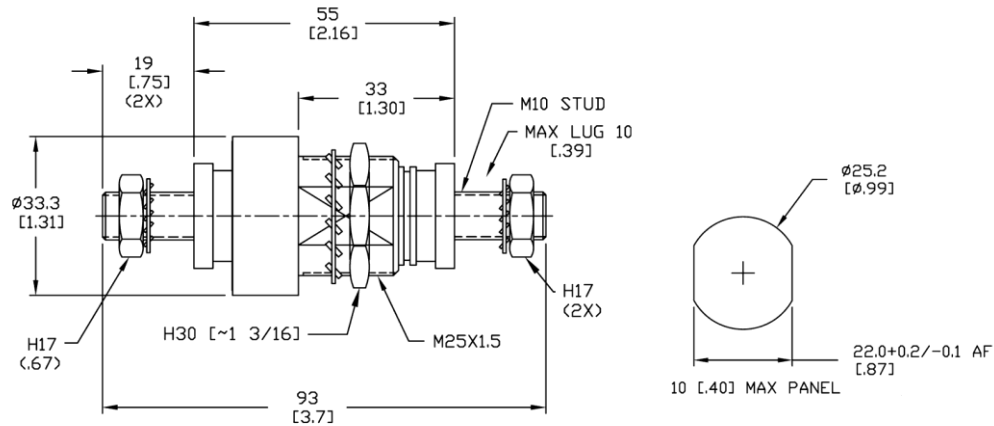

Component	Material	Finish
Metal Parts	Copper Alloy	Nickel
Insulator	FR4 or Nylon	-

### Mounting

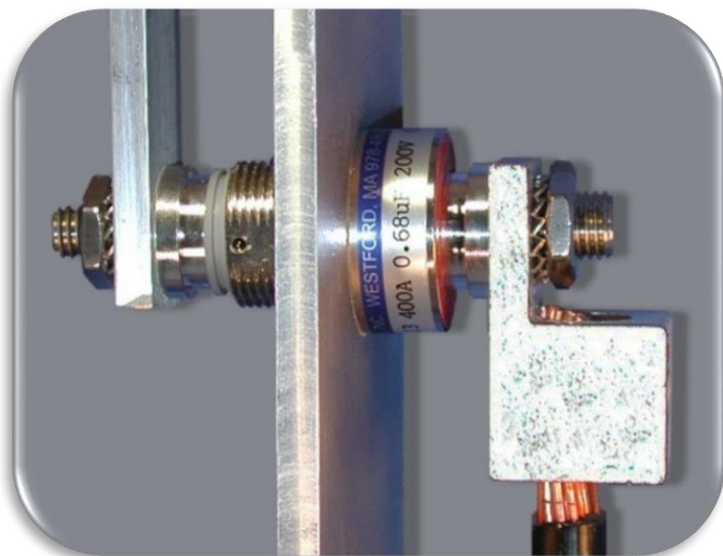

#### INSTALLATION NOTE:

Always place current-carrying wire lug or busbar directly against the flat electrode face of the HPR400. Do not use any hardware (lockwashers, extra nuts, etc.) between the current-carrying conductor and this flat electrode face.

#### Installation Torque Recommendations

Electrode Lug Nut (e) Torque: 200 in-lbs (22 N·m)  
Mounting Panel Nut (c) Torque: 300 in-lbs (34 N·m)

### Part Number

Device	Current	Capacitance	Tolerance	Voltage	Series
HPR	400	XXXX	X	XX	X

**Device** HPR High Current Feedthrough Filter

**Current** Current rating in amperes

**Capacitance** in picofarads, first two digits are significant, last two digits are number of zeros  
e.g. 2203 = 22,000pF / 4704 = .47μF

**Tolerance** Capacitor Code: Z= +80%/-20% (Standard), M= +/-20%, K= +/-10%, J=+/-5%

**Voltage** Rating Code: 05=50V, 10=100V, 20=200V, 50=500V, 1K=1000V, 1A=120Vac, 2A=240Vac

**Series** Optional series designator

**Example:** HPR4001004Z10 = Feedthrough Filter / 400A / 0.10uF / +80%/-20% / 100Vdc

### Safety Tips

- ✓ The filter should be mounted in a grounded shielding panel
- ✓ Tighten the electrode nuts to the torque specified
- ✓ Cover exposed electrode nuts
- ✓ Observe temperature, current, & voltage limits
- ✓ Always install lug or busbar directly against center boss/flat