

REVISION HISTORY

REVISION	DATE	COMMENT

- NOTES:**
- MATERIALS: "G" STYLE**
 - SHELL, FERRULE
BRASS PER QQ-B-626
FINISH: GOLD, OVER
ELECTROLESS NICKEL
PER MIL-G-45204, TYP 2, CLASS 1
 - INSERT
PEEK, GLASS FILLED PER
MIL-P-46183
 - CONTACTS
COPPER ALLOY
FINISH: GOLD PER MIL-G-45204
 - GASKETS (OPTIONAL)
SILICONE RUBBER PER AMS 3304
 - ALTERNATE SHELL MATERIALS
AND FINISHES:
"M" STYLE: BRASS, WITH
ELECTROLESS NICKEL FINISH
PER AMS-C-26074, CLASS 4, GRADE B
"A" STYLE: BRASS, WITH GOLD PLATE,
BLACK CHROMATE
"K" STYLE: STAINLESS STEEL,
300 SERIES, WITH PASSIVATION

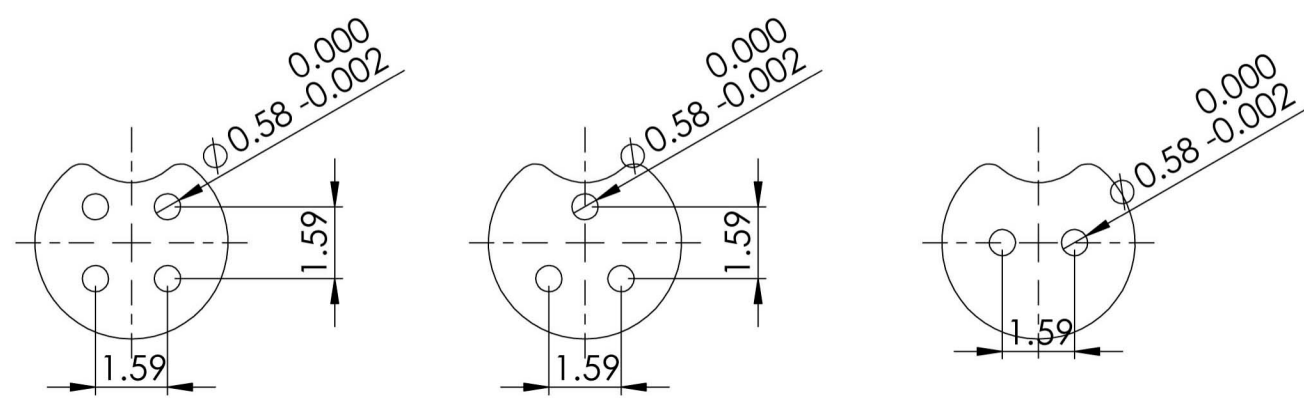
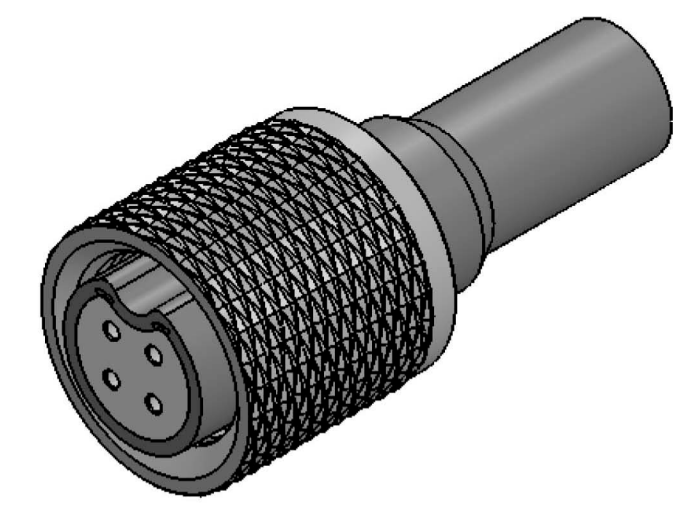
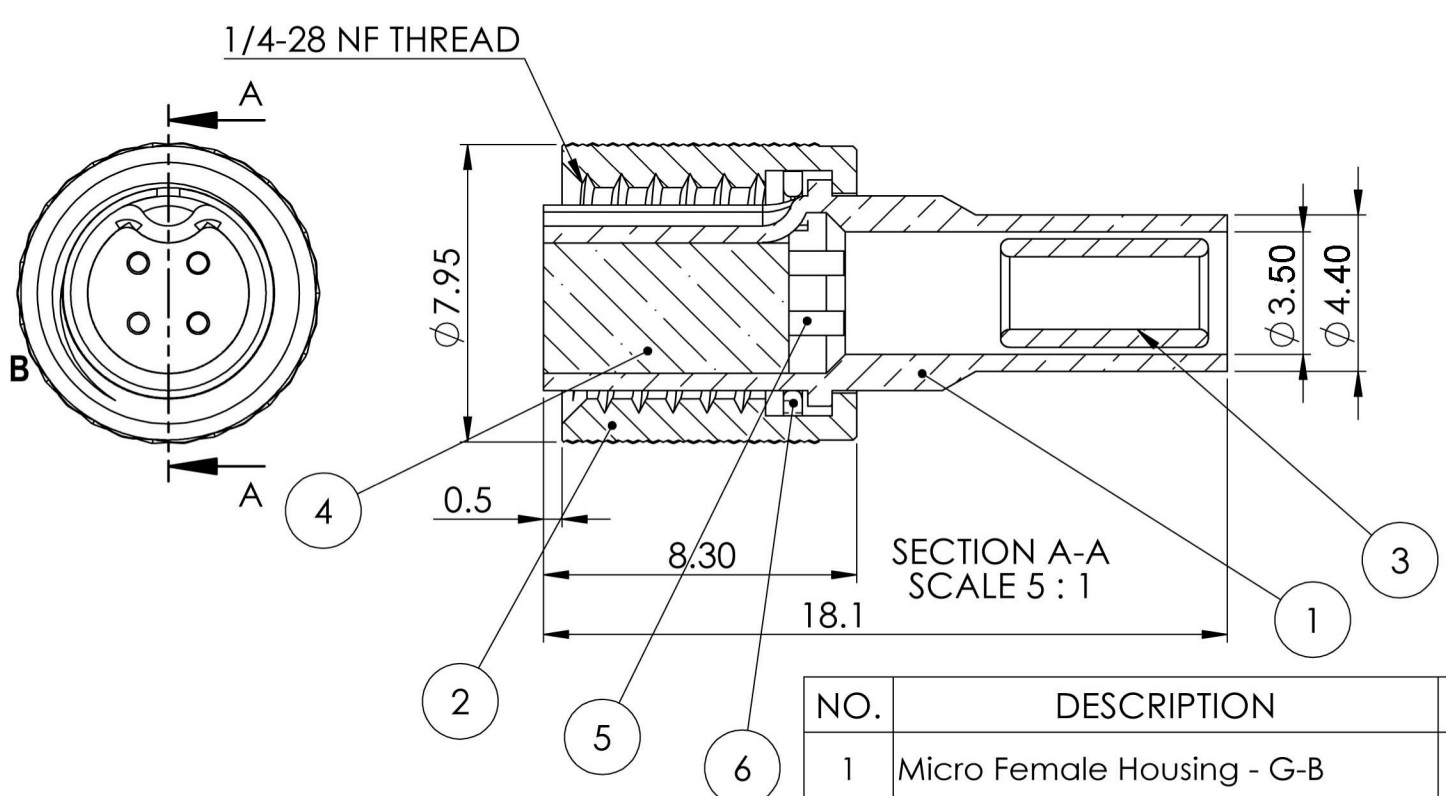

4 POSITION

3 POSITION
LAYOUT

2 POSITION

NO.	DESCRIPTION	QTY	MATERIAL	PLATING	Remarks
1	Micro Female Housing - G-B	1	BRASS	GOLD PLATE	
2	Micro Coupling Ring - G-B	1	BRASS	GOLD PLATE	
3	Micro Ferrule - G-B	1	BRASS	GOLD PLATE	
4	Micro Female Insert - G-B	1	PEEK	1	30% GLASS FILL
5	Micro female pin - G-B	4	COPPER ALLOY	GOLD PLATE	
6	Micro Washer - G-B	1	STAINLESS STEEL	PASSIVATED	

UNLESS OTHERWISE NOTED:
DIMENSIONS ARE IN MILLIMETERS
DO NOT SCALE THIS DRAWING

.X DECIMALS ARE ± 0.5
.XX DECIMALS ARE ± 0.25
.XXX DECIMALS ARE ± 0.13
ANGLES ARE ± 0.5°

DRAWING	MILSPECWEST-MICRO PRODUCTS	
CHECKED	DESCRIPTION: MSW PLUG	
Q.A.	DWG. NO. MSW-G-B***	REVISION: 5
	SHEET 1 OF 2	

THIS DOCUMENT IS SOLE PROPERTY OF MILSPECWEST AND IS ISSUED IN STRICT CONFIDENCE THAT IT WILL NOT BE REPRODUCED IN ANY WAY OR USED TO SOLICIT BUSINESS OF A COMPETITIVE NATURE. DISTRIBUTION OF THIS DOCUMENT IS PROHIBITED UNLESS WRITTEN CONSENT IS OBTAINED FROM MILSPECWEST. THIS DOCUMENT IS SUITABLE FOR ENGINEERING EVALUATION AND MAY BE USED IN TECHNICAL SPECIFICATIONS.

NOTES:

- 1. MATERIALS: "G" STYLE
 - 1.1 SHELL, FERRULE
BRASS PER QQ-B-626
FINISH: GOLD, OVER
ELECTROLESS NICKEL
PER MIL-G-45204, TYP 2, CLASS 1
 - 1.2 INSERT
PEEK, GLASS FILLED PER
MIL-P-46183
 - 1.3 CONTACTS
COPPER ALLOY
FINISH: GOLD PER MIL-G-45204
 - 1.4 GASKETS
SILICONE RUBBER PER AMS 3304
 - 1.5 ALTERNATE SHELL MATERIALS
AND FINISHES:
"M" STYLE: BRASS, WITH
ELECTROLESS NICKEL FINISH
PER AMS-C-26074, CLASS 4, GRADE B
"A" STYLE: BRASS, WITH GOLD PLATE,
BLACK CHROMATE
"K" STYLE: STAINLESS STEEL,
300 SERIES, WITH PASSIVATION

PART NUMBER BREAKDOWN

MSW - G - B - 04 S

P = PIN
S = SOCKET

NUMBER OF CONTACTS
02
03
04

SHELL SIZE (SEE TABLE 2)
BODY STYLE

- B = PLUG
- R = IN LINE RECEPTACLE
- C = STRAIGHT PCB MOUNT
- D = FRONT PANEL JAM NUT MOUNT
- E = FRONT PANEL SOLDER MOUNT
- F = RIGHT ANGLE PCB MOUNT

FINISH AND MATERIAL

- G = BRASS WITH GOLD OVER ELEC NICKEL
- M = BRASS WITH ELECTROLESS NICKEL
- A = BRASS WITH BLACK ANODIZE
- K = STAINLESS STEEL WITH PASSIVATION

BASIC PART NUMBER

SPECIFICATIONS:

ELECTRICAL:

ELECTRICAL RESISTANCE: 10,000 M OHMS PER MIL-C-22557
 RATED WORKING VOLTAGE: 400V @ SEA LEVEL
 DIELECTRIC WITHSTANDING: 1,000 V @ SEA LEVEL PER MIL-C-22557
 CONTACT VOLTAGE DROP: 4 mV @ 1 AMP PER MIL-C-22557
 CONTACT RESISTANCE: 4 MOHM @ 1 AMP PER MIL-C-22557
 CONTACT CURRENT RATING: 3 AMP

ENVIRONMENTAL:

VIBRATION: MIL STD 202A METHOD 204 TEST COND B (15G's)
 NO DISCONTINUITY IN EXCESS OF 1 MICROSECOND
 SHOCK: MIL STD 202 METHOD 202, 300 G's NO EVIDENCE OF DAMAGE
 TEMPERATURE CYCLING: MIL STD 202 METHOD 102, CONDITION C
 CORROSION (SALT SPRAY): MIL STD 202 METHOD 10, COND B 5% SALT SOLUTION
 MOISTURE RESISTANCE: MIL STD 202C METHOD 106B, OMITTING STEO 7B
 AND HIGH HUMIDITY TESTS

MECHANICAL:

CONTACTS: CONTACTS ARE CONTRAINED IN BOTH DIRECTIONS
 ENGAGING FORCE: 0.8N PER CONTACT
 COUPLING RETENTION TORQUE: 60 Nmm
 CONTACT DURABILITY: 5000 CYCLES WITHH CONTACT RESISTANCE
 WITHIN MIN MIL-C-22557
 CABLE RETENTION: SEPARATION FORCE EQUAL TO BREAKING STRENGTH
 OF SHIELD OF THE CABLE PER MIL-C-22557

UNLESS OTHERWISE NOTED: DIMENSIONS ARE IN MILLIMETERS DO NOT SCALE THIS DRAWING .X DECIMALS ARE ±0.5 .XX DECIMALS ARE ±0.25 .XXX DECIMALS ARE ±0.13 ANGLES ARE ±0.5°	DRAWING	SC	MILSPECWEST - MICRO PRODUCTS CAGE CODE: 3HD49	
	CHECKED	TS	DESCRIPTION: MICRO PLUG	
	Q.A.	KB	DWG. NO. MSW*-B-***	REVISION: 4 SHEET 2 OF 2

THIS DOCUMENT IS SOLE PROPERTY OF MILSPECWEST AND IS ISSUED IN STRICT CONFIDENCE THAT IT WILL NOT BE REPRODUCED IN ANY WAY OR USED TO SOLICIT BUSINESS OF A COMPETITIVE NATURE. DISTRIBUTION OF THIS DOCUMENT IS PROHIBITED UNLESS WRITTEN CONSENT IS OBTAINED FROM MILSPECWEST. THIS DOCUMENT IS SUITABLE FOR ENGINEERING EVALUATION AND MAY BE USED IN TECHNICAL SPECIFICATIONS.