



MULTI SPIDER (ORG4572)

GNSS RECEIVER MODULE

EVALUATION KIT

Datasheet

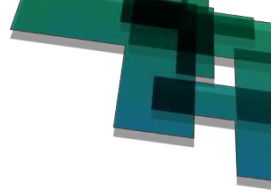

INDEX

1.	SCOPE.....	4
2.	DISCLAIMER.....	4
3.	SAFETY INFORMATION.....	4
4.	ESD SENSITIVITY.....	4
5.	CONTACT INFORMATION.....	4
6.	RELATED DOCUMENTATION.....	4
7.	REVISION HISTORY.....	5
8.	ABOUT SPIDER FAMILY.....	5
9.	ABOUT MULTI SPIDER MODULE.....	5
10.	ABOUT ORIGINGPS.....	6
11.	DESCRIPTION.....	6
12.	SCHEMATICS.....	7
12.1.	MAIN BOARD SCHEMATICS.....	7
12.2.	INTERFACE ADAPTOR SCHEMATICS.....	8
13.	BILL OF MATERIALS.....	9
13.1.	MAIN BOARD BILL OF MATERIALS.....	9
13.2.	INTERFACE ADAPTOR BILL OF MATERIALS.....	9
14.	ASSEMBLY AND LAYOUT.....	10
14.1.	MAIN BOARD PCB.....	10
14.2.	INTERFACE ADAPTOR PCB.....	12
15.	TTL-232R-3V3 USB-Serial CONVERTER CABLE.....	15
16.	ORG9802 MINIATURE PASSIVE ANTENNA ASSEMBLY.....	16
16.1.	GENERAL.....	16
16.2.	MECHANICAL SPECIFICATIONS.....	16
16.3.	ELECTRICAL SPECIFICATIONS.....	17
17.	ORG9805 EXTERNAL ACTIVE ANTENNA.....	18
17.1.	DESCRIPTION.....	18
17.2.	FEATURES.....	18
17.3.	BENEFITS.....	18
17.4.	BLOCK DIAGRAM.....	18
17.5.	ELECTRICAL SPECIFICATIONS.....	19
17.6.	MECHANICAL SPECIFICATIONS.....	20
18.	I-PEX MHFIII TO SMA-TYPE COAXIAL CABLE ADAPTOR.....	21

TABLE INDEX

TABLE 1 – RELATED DOCUMENTATION.....	4
TABLE 2 – REVISION HISTORY.....	5
TABLE 3 – MAIN BOARD BILL OF MATERIALS.....	9
TABLE 4 – INTERFACE ADAPTOR BILL OF MATERIALS.....	9
TABLE 5 – USB-SERIAL CONVERTER CABLE HEADER PIN-OUT.....	15
TABLE 6 – USB-SERIAL CONVERTER CABLE OPERATING PARAMETERS.....	15
TABLE 7 – ORG9802 MECHANICAL SPECIFICATIONS.....	16
TABLE 8 – ORG9802 ELECTRICAL SPECIFICATIONS.....	17
TABLE 9 – ORG9805 ELECTRICAL SPECIFICATIONS.....	19
TABLE 10 – ORG9805 MECHANICAL SPECIFICATIONS.....	20

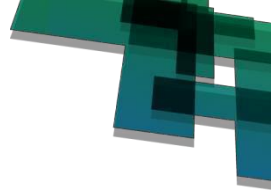
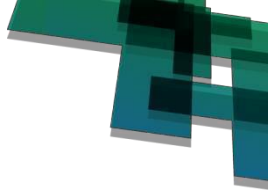

FIGURE INDEX

FIGURE 1 – MAIN BOARD SCHEMATICS	7
FIGURE 2 – INTERFACE ADAPTOR SCHEMATICS.....	8
FIGURE 3 – MAIN BOARD COMPONENTS PLACEMENT	10
FIGURE 4 – MAIN BOARD SOLDER MASK	10
FIGURE 5 – MAIN BOARD TOP LAYER ROUTING	11
FIGURE 6 – MAIN BOARD BOTTOM LAYER ROUTING	11
FIGURE 7 – INTERFACE ADAPTOR BOARD COMPONENTS PLACEMENT	12
FIGURE 8 – INTERFACE ADAPTOR BOARD SOLDER MASK	12
FIGURE 9 – INTERFACE ADAPTOR BOARD TOP LAYER ROUTING	13
FIGURE 10 – INTERFACE ADAPTOR INNER LAYER 1 ROUTING	13
FIGURE 11 – INTERFACE ADAPTOR INNER LAYER 2 ROUTING	14
FIGURE 12 – INTERFACE ADAPTOR BOTTOM LAYER ROUTING.....	14
FIGURE 13 – PIN HEADER SOCKET BOTTOM VIEW	15
FIGURE 14 – ORG9802 MECHANICAL OUTLINE.....	16
FIGURE 15 – ORG9802 S11 LOG MAGNITUDE	17
FIGURE 16 – ORG9805 S11 LOG MAGNITUDE	18
FIGURE 17 – ORG9805 BLOCK DIAGRAM	19
FIGURE 18 – ORG9805 MECHANICAL OUTLINE	20
FIGURE 19 – I-PEX MHFIII TO SMA-TYPE ADAPTOR MECHANICAL OUTLINE	21



1. SCOPE

This document describes the features and specifications of Multi Spider ORG4572 evaluation kit.

2. DISCLAIMER

All trademarks are properties of their respective owners.

Performance characteristics listed in this document do not constitute a warranty or guarantee of product performance. OriginGPS assumes no liability or responsibility for any claims or damages arising out of the use of this document, or from the use of integrated circuits based on this document.

OriginGPS assumes no liability or responsibility for unintentional inaccuracies or omissions in this document.

OriginGPS reserves the right to make changes in its products, specifications and other information at any time without notice.

OriginGPS reserves the right to conduct, from time to time, and at its sole discretion, firmware upgrades.

As long as those FW improvements have no material change on end customers, PCN may not be issued.

OriginGPS navigation products are not recommended to use in life saving or life sustaining applications.

3. SAFETY INFORMATION

Improper handling and use can cause permanent damage to the product.

4. ESD SENSITIVITY

This product is ESD sensitive device and must be handled with care.



5. CONTACT INFORMATION

Support - support@origingps.com or [Online Form](#)

Marketing and sales - marketing@origingps.com

Web – www.origingps.com

6. RELATED DOCUMENTATION

No	DOCUMENT NAME
1	Multi Spider – ORG4572 Datasheet
2	Spider and Hornet - NMEA Protocol Reference Manual
3	Spider and Hornet - OSP® Reference Manual
4	Spider and Hornet - OSP® GNSS Extensions Reference Manual
5	Spider and Hornet - Low Power Modes Application Note
6	Spider and Hornet - Client Generated Extended Ephemeris Application Note
7	Spider and Hornet - Server Generated Extended Ephemeris Application Note
8	Spider and Hornet - Ephemeris Push Application Note

TABLE 1 – RELATED DOCUMENTATION



7. REVISION HISTORY

REVISION	DATE	CHANGE DESCRIPTION
A01	January 12, 2011	First release
2.0	June 14, 2015	Format Update

TABLE 2 – REVISION HISTORY

8. ABOUT SPIDER FAMILY

OriginGPS GNSS receiver modules have been designed to address markets where size, weight, stand-alone operation, highest level of integration, power consumption and design flexibility - all are very important. OriginGPS' Spider family breaks size barrier, offering the industry's smallest fully-integrated, highly-sensitive GPS / GNSS modules.

Spider family features OriginGPS' proprietary NFZ™ technology for high sensitivity and noise immunity even under marginal signal condition, commonly found in urban canyons, under dense foliage or when the receiver's position in space rapidly changes.

Spider family enables the shortest TTM (Time-To-Market) with minimal design risks.

Just connect an antenna and power supply on a 2-layer PCB.

9. ABOUT MULTISPIDER MODULE

Multi Spider is a complete SiP featuring miniature LGA SMT footprint designed to commit unique integration features for high volume cost sensitive applications.

Designed to support ultra-compact applications such as smart watches, wearable devices, trackers and digital cameras, ORG4572 module is a miniature multi-channel GPS/ GLONASS with SBAS, QZSS and other regional overlay systems receiver that continuously tracks all satellites in view, providing real-time positioning data in industry's standard NMEA format.

ORG4572 module offers superior sensitivity and outstanding performance, achieving rapid TTFF in less than one second, accuracy of approximately one meter, and tracking sensitivity of -165dBm.

Sized only 7mm x 7mm the ORG4572 GNSS module is pin and footprint compatible with OriginGPS' popular ORG4472 GPS module.

ORG4572 module integrates LNA, SAW filter, TCXO, RTC crystal and RF shield with market-leading SiRFstarV™ GNSS SoC.

ORG4572 module is capable to decode extremely weak satellite signals simultaneously from GPS and GLONASS thereby offering best-in-class positioning availability, unparalleled accuracy and extremely fast fixes under challenging signal conditions, such as in built-up urban areas, dense foliage or even indoor.

Internal GNSS SoC incorporating high-performance microprocessor and sophisticated GNSS firmware keeps positioning payload off the host allowing integration in embedded solutions even with low computing resources.

Innovative architecture can detect changes in context, temperature, and satellite signals to achieve a state of near continuous availability by maintaining and opportunistically updating its internal fine time, frequency, and ephemeris data while consuming mere microwatts of battery power.



10. ABOUT ORIGINGPS

OriginGPS is a world leading designer, manufacturer and supplier of miniature positioning modules, antenna modules and antenna solutions.

OriginGPS modules introduce unparalleled sensitivity and noise immunity by incorporating Noise Free Zone system (NFZ™) proprietary technology for faster position fix and navigation stability even under challenging satellite signal conditions.

Founded in 2006, OriginGPS is specializing in development of unique technologies that miniaturize RF modules, thereby addressing the market need for smaller wireless solutions.

11. DESCRIPTION

Evaluation Kit of the ORG4572 GNSS Module comprises the Demo Board, USB to UART Serial Converter Cable, ORG9802 Miniature Passive Antenna Assembly, I-PEX MHFIII to SMA-type Coaxial Cable Adaptor, ORG9805 External Active Antenna, support Disk-on-key with GPS simulator software for PC and documentation. The Demo Board assembly is built of Main Board, incorporating 3.3V LDO voltage regulator, UART connector, push-button tactile switch for Push-To-Fix™ interrupt and various test points.

The ORG4572 GNSS Module is soldered onto the Main Board through the Interface Adaptor.

The Interface Adaptor includes a single-bit buffer for voltage level translation of TX line, 1.8V LDO voltage regulator, Load Switch for active antenna T-bias and a voltage supervisor for autonomous power-on pulse generation.

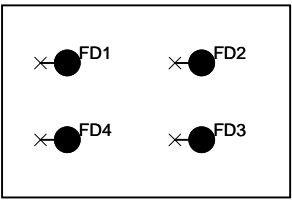
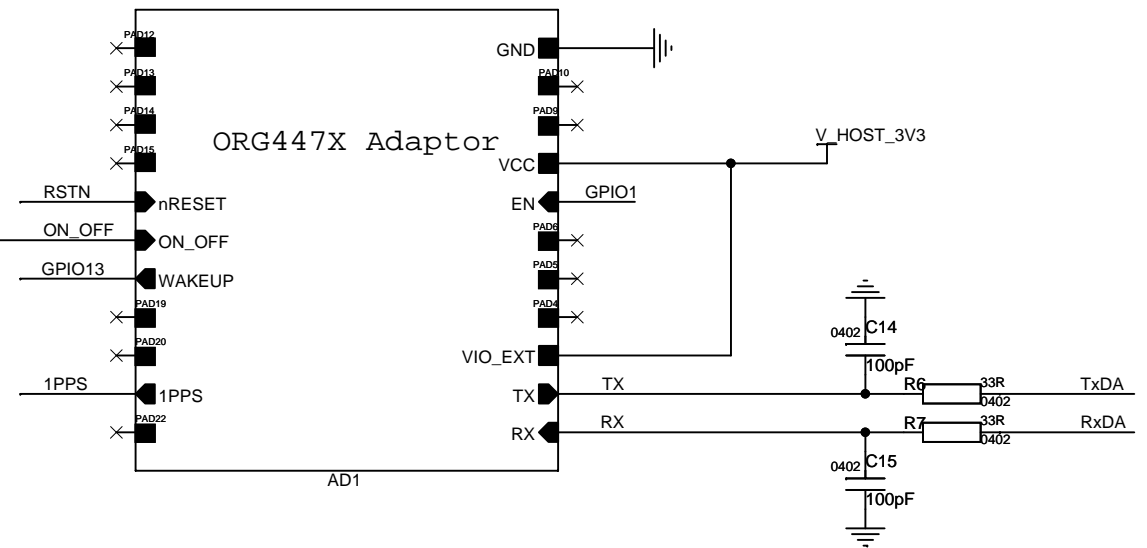
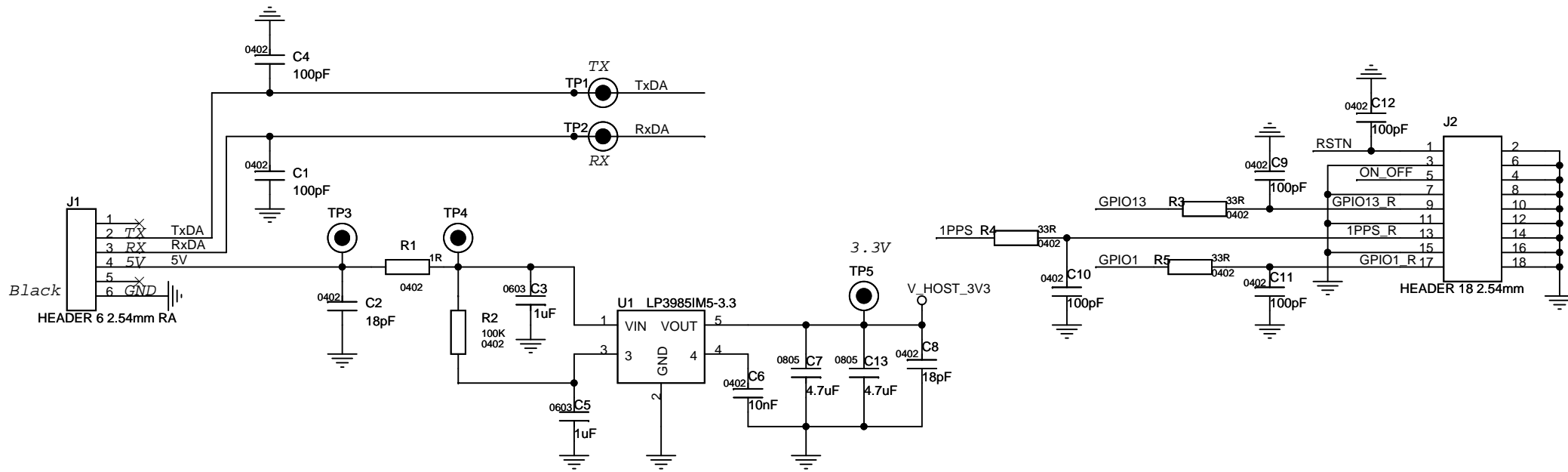

		Project	
		ORG447X UART Evaluation Kit	
Title			
ORG447X UART Demo Board			
Size	Document Number	Authored By:	Rev
A4	PD-ORG447X-AD1-DBUA	I. Divinsky	A00
Date:	Sunday, September 12, 2010		Sheet 1 of 1

Active Antenna Bias Assembly Option 5

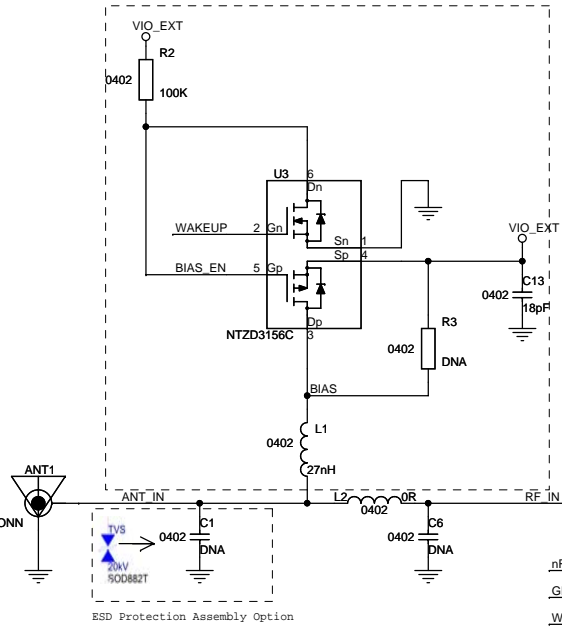

ESD Protection Assembly Option

Do Not Assembly

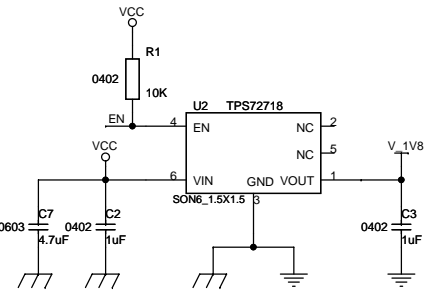
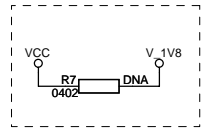

DC-DC Buck Regulator Assembly Option 2

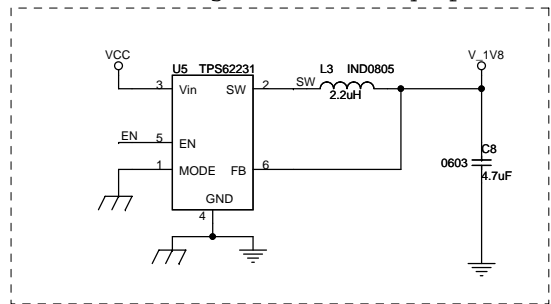

ON_OFF Rising Edge Generator Assembly Option 4

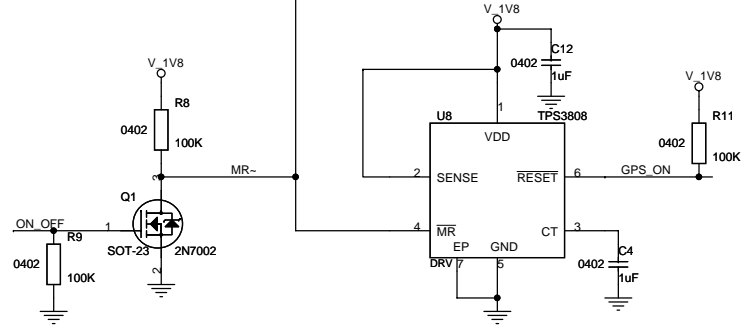
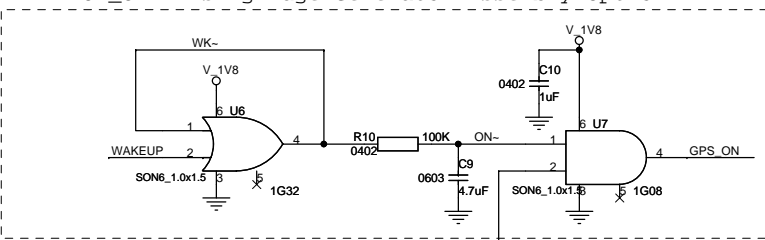

		Project ORG447X-AD1	
		Title ORG447X Adaptor	
Size A3	Document Number PD-ORG-447XAD1-A00	Authored By: I. Divinsky	Rev A00
Date: Sunday, September 12, 2010	Sheet 1	of 1	

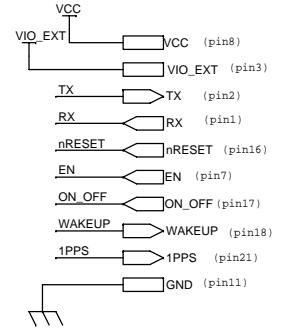



13. BILL OF MATERIALS

13.1 MAIN BOARD BILL OF MATERIALS

Reference	Value	Description	P/N	MFG
C2, C8	18pF	CAP SMT 0402 18pF ±5% 50V COG	GRM1555C1H180JZ01D	MURATA
C1,C4, C9, C10, C11, C12, C14, C15	100pF	CAP SMT 0402 100pF ±5% 50V COG	GRM1555C1H101JA01D	MURATA
C6	10nF	CAP SMT 0402 10nF ±10% 25V X7R	GRM155R71E103KA01D	MURATA
C3, C5	1µF	CAP SMT 0603 1µF ±10% 10V X5R	GRM188R60J105KA01J	MURATA
C7, C13	4.7µF	CAP SMT 0805 4.7µF ±10% 16V X5R	GRM21BR61C475KA88L	MURATA
R1	1Ω	RES SMT 0402 1Ω ±1%	RM04FTN0010	TA-I
R3, R4, R5, R6, R7	33Ω	RES SMT 0402 33Ω ±1%	RM04FTN0330	TA-I
R2	100KΩ	RES SMT 0402 100KΩ ±1%	RM04FTN1003	TA-I
J1	HDR	HEADER 6 POS. 0.1" RIGHT ANGLE	2211S-06G-F1	NELTRON
SW1	TSW	TACT SWITCH SMT	KSC222JLFS	C&K
U1	LDO	LDO REG. SMT SOT23-5 3.3V 200mA	TLV70033DDCT	TI

TABLE 3 - MAIN BOARD BILL OF MATERIALS

13.2 INTERFACE ADAPTOR BILL OF MATERIALS

Reference	Value	Description	P/N	MFG
ANT1	ANT_CONN	Ultra Small SMD Coaxial Conn.	W.FL	HIROSE
C2,C3,C4,C5,C12	1uF	CAP SMT 1uF 10V 10% X5R 0402	GRM155R61A105KE15	MURATA
C7,C8	4.7uF	CAP SMT 4.7uF 6.3V ±10% X5R 0603	GRM155R60G475ME87D	MURATA
C11,C13	18pF	CAP SMT 18pF 50V ±5% COG 0402	GRM1555C1H180JZ01D	MURATA
L2,R6	0R	RESISTOR CHIP METAL FILM 0402 0.063W	CRCW04020RJK	VISHAY
L1	27nH	IND SMT 27nH 0402	LQG15HS27NJ02	MURATA
Q1	2N7002	N-CH 0.38A 60V SOT23 Power MOSFET	2N7002KT1G	ON
R8,R9,R11,R2	100K	RESISTOR CHIP METAL FILM 0402 0.063W	CRCW0402100KJK	VISHAY
R1,R4	10K	RESISTOR CHIP METAL FILM 0402 0.063W	CRCW040210KJK	VISHAY
R13	33R	RESISTOR CHIP METAL FILM 0402 0.063W	CRCW0402100KJK	VISHAY
U1	ORG447X	Minuature GNSS Engine Module	ORG447X	ORIGINGP
U2	TPS72718	1.8V 200mA Low Iq Low N RF LDO	TPS72718DSER	TI
U4	NLU1GT126	Single Buffer W. 3-STATE	NLU1GT126CMX1TCG	ON
U8	TPS3808	Low Iq Programmable Delay Supervisor	TPS3808G18DRVR	TI
U3	NTZD3156C	Compl. N- P-Ch. MOSFET w Integr PUR PDR ESD Protection	NTZD3156CT1G	ON

TABLE 4 - INTERFACE ADAPTOR BILL OF MATERIALS

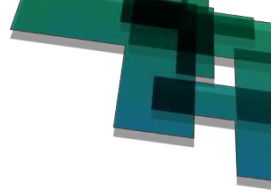

14. ASSEMBLY AND LAYOUT

14.1 MAIN BOARD PCB

Main Board for the ORG4572 GNSS Module is 2-layer 1.6mm thickness FR4 PCB.

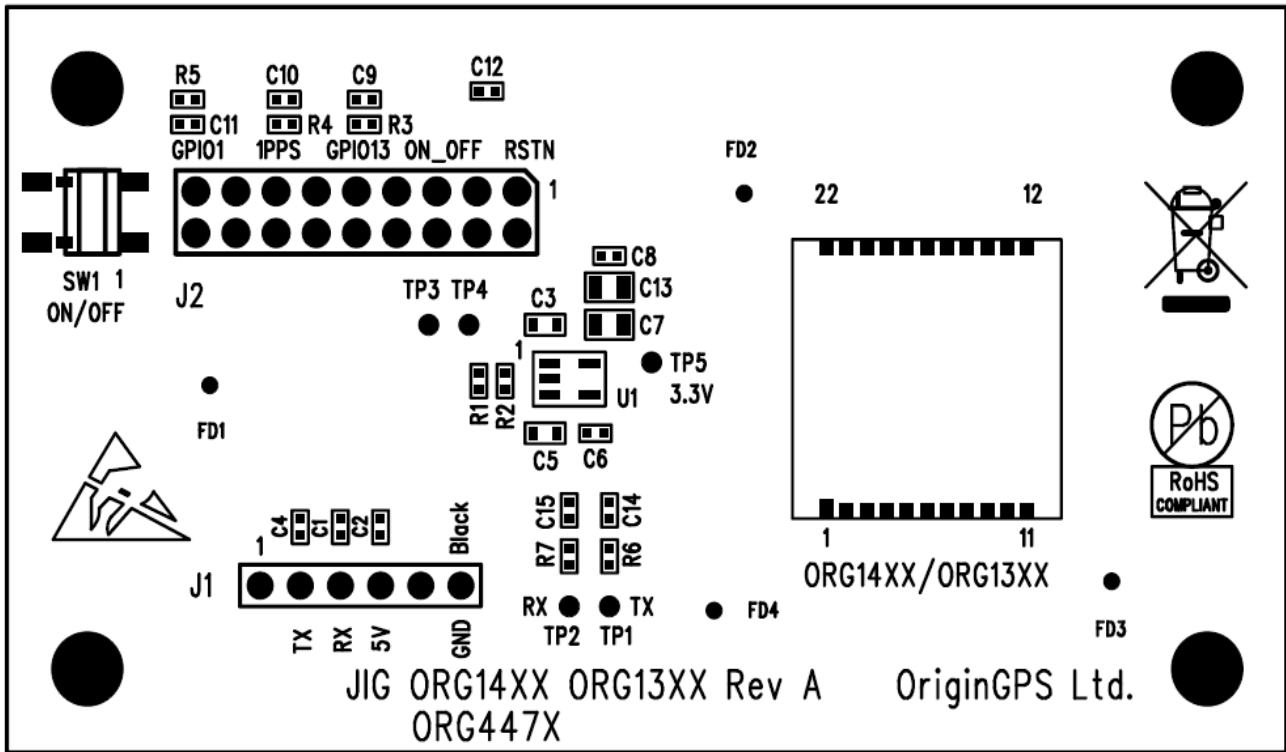

FIGURE 3 - MAIN BOARD COMPONENTS PLACEMENT

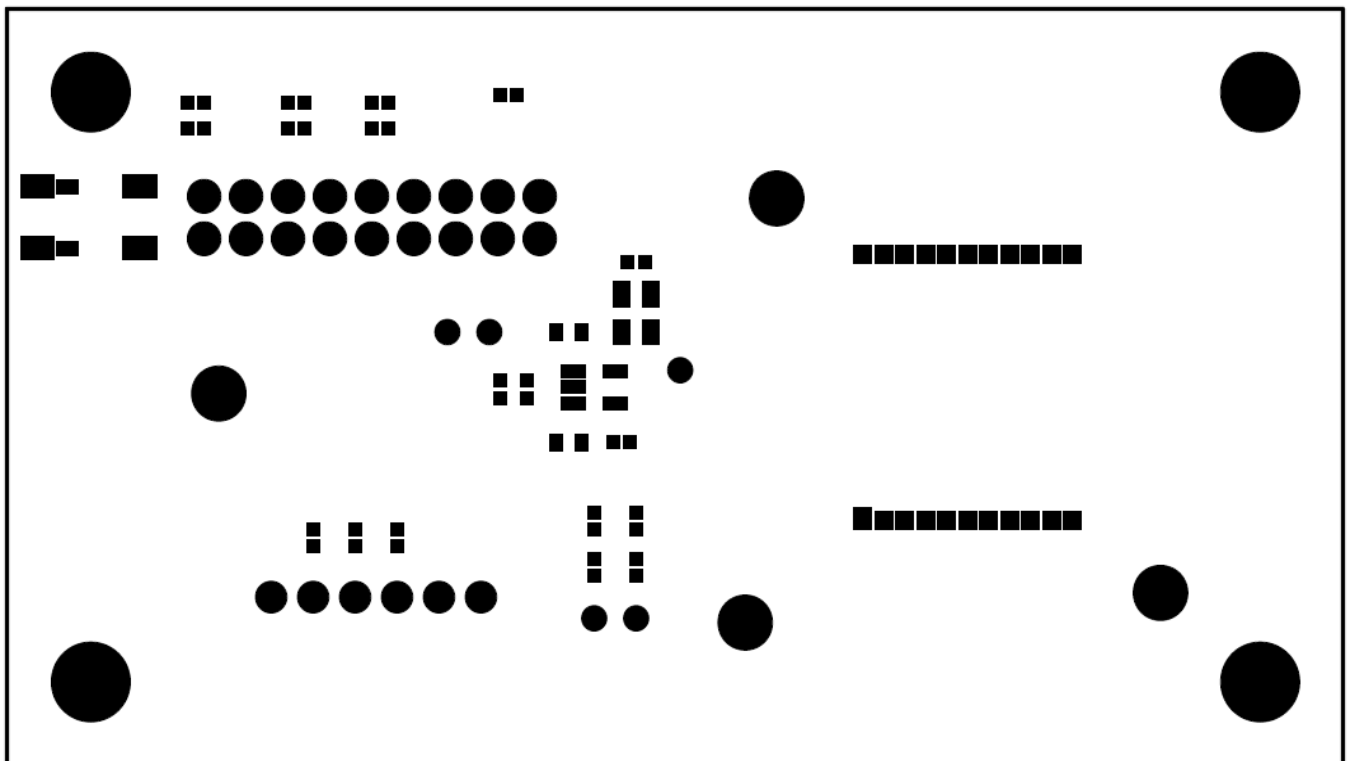

FIGURE 4 - MAIN BOARD SOLDER MASK

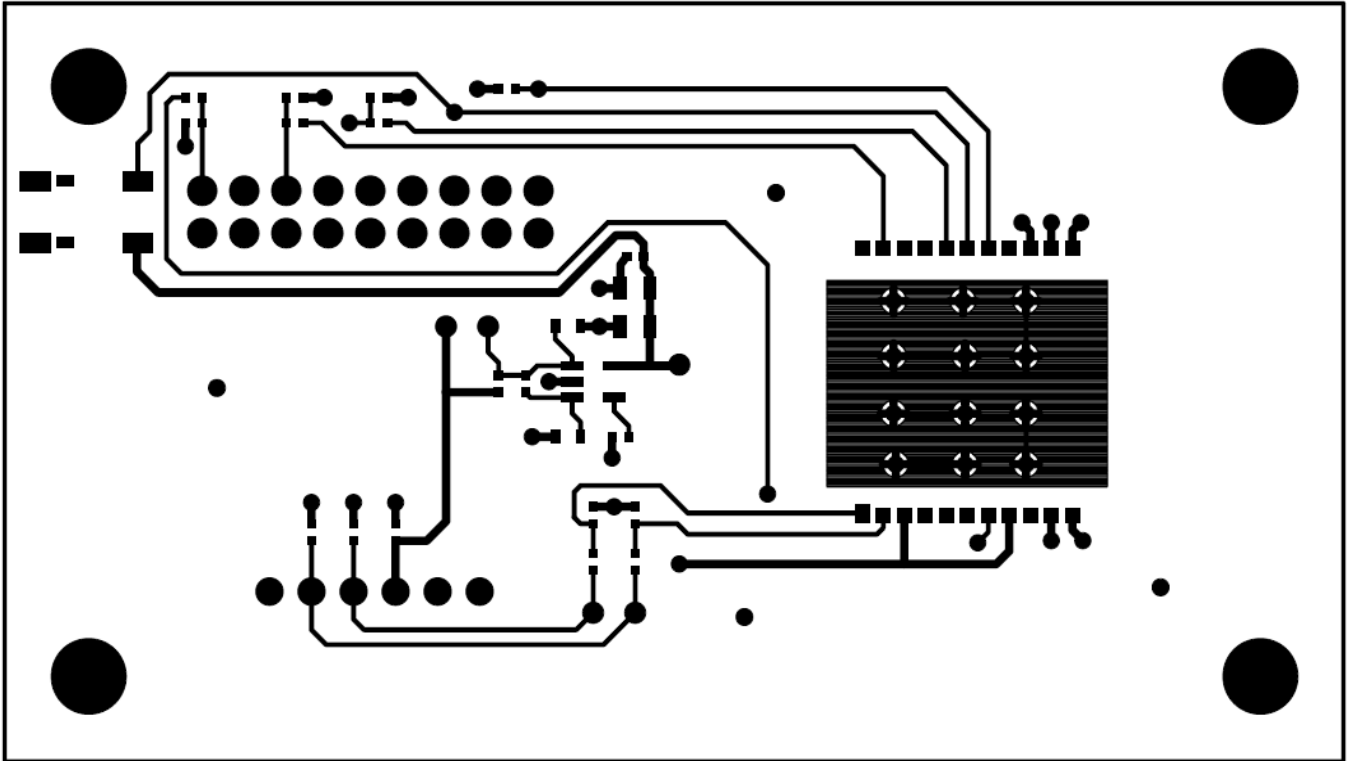
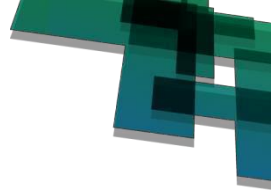

FIGURE 5 – MAIN BOARD TOP LAYER ROUTING

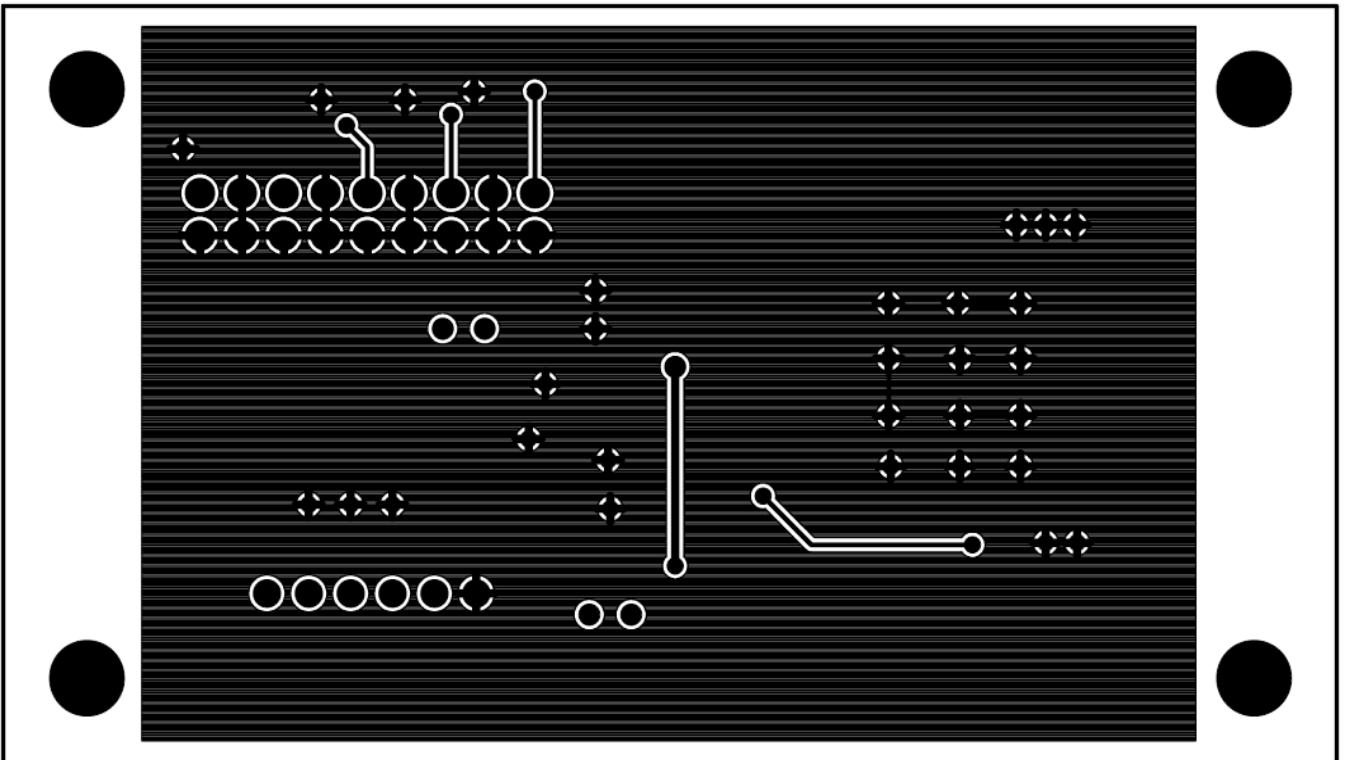
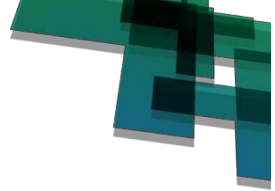

FIGURE 6 – MAIN BOARD BOTTOM LAYER ROUTING



14.2 INTERFACE ADAPTOR PCB

Interface Adaptor Board for the ORG4572 GNSS Module is 17mm x 17mm 22 pads 4 layers 0.6mm thickness FR4 PCB.

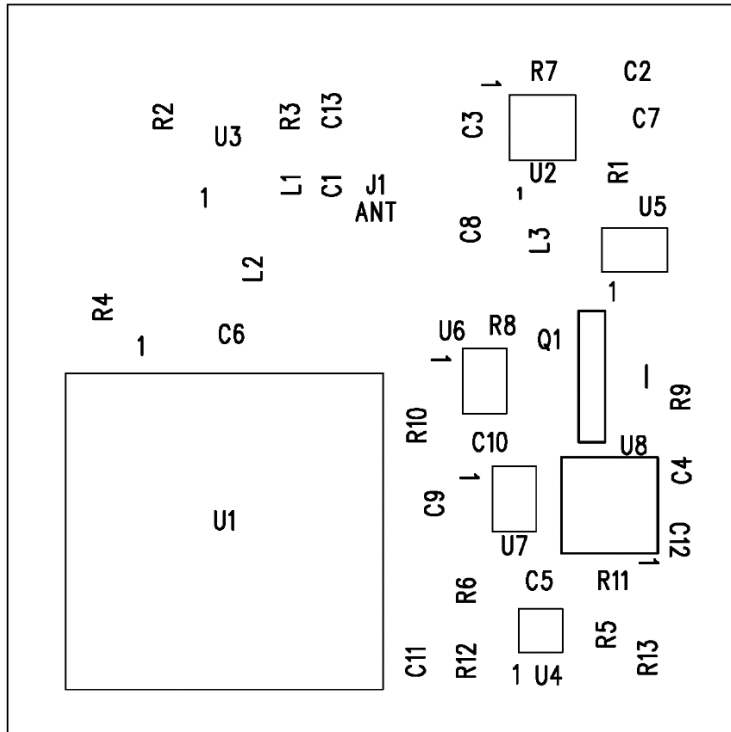

FIGURE 7 - INTERFACE ADAPTOR BOARD COMPONENTS PLACEMENT

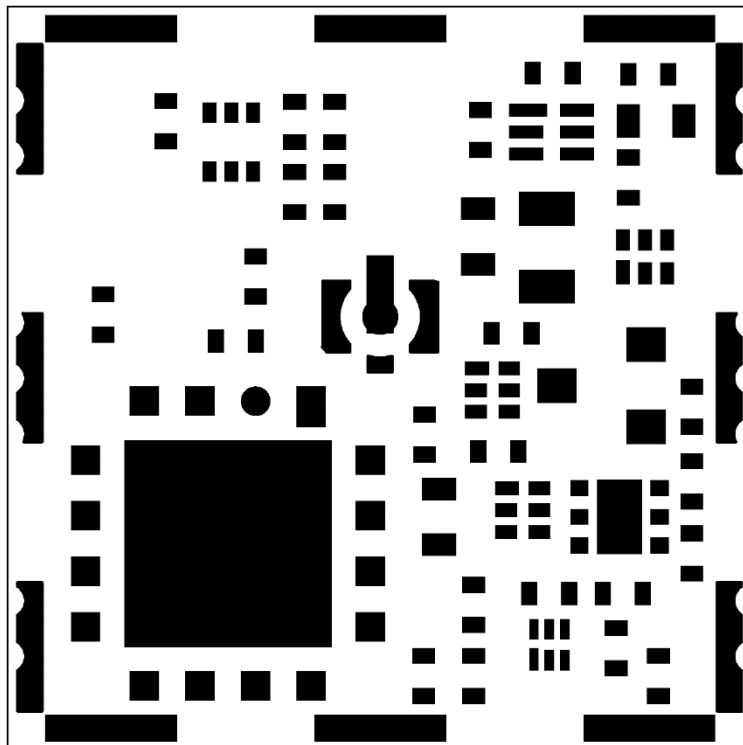

FIGURE 8 - INTERFACE ADAPTOR BOARD SOLDER MASK

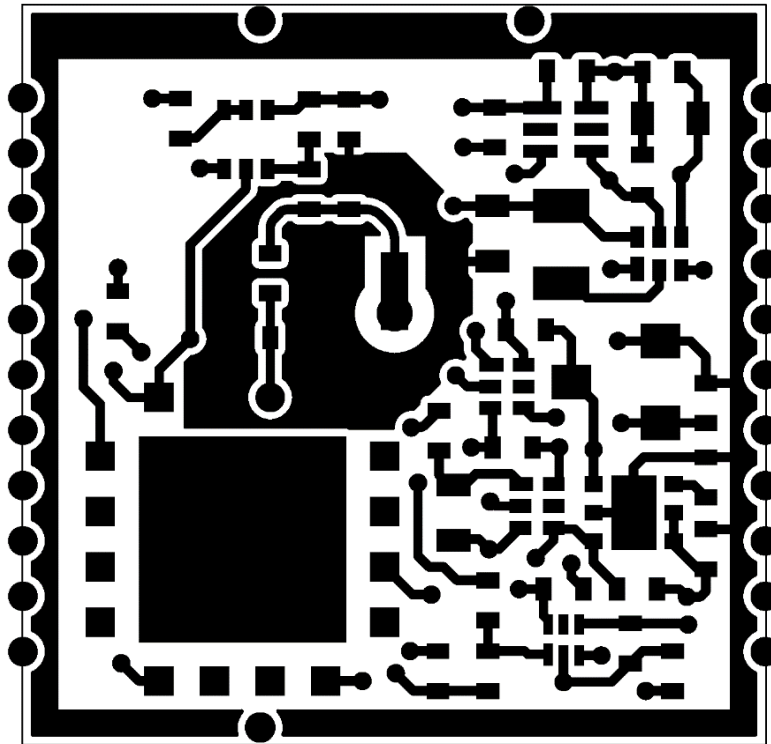
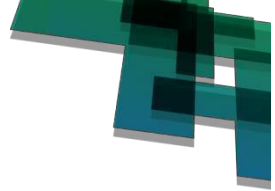

FIGURE 9 - INTERFACE ADAPTOR BOARD TOP LAYER ROUTING

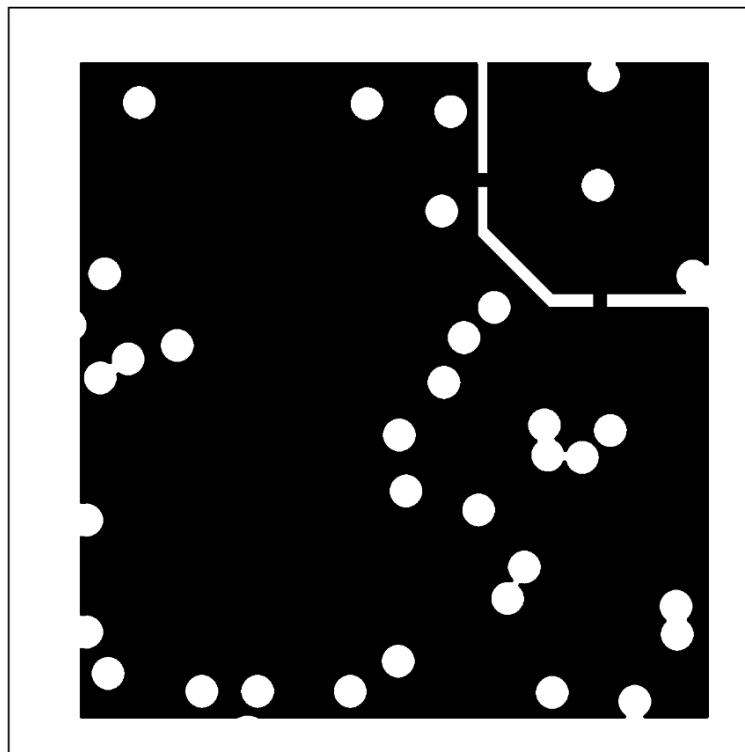

FIGURE 10 - INTERFACE ADAPTOR INNER LAYER 1 ROUTING

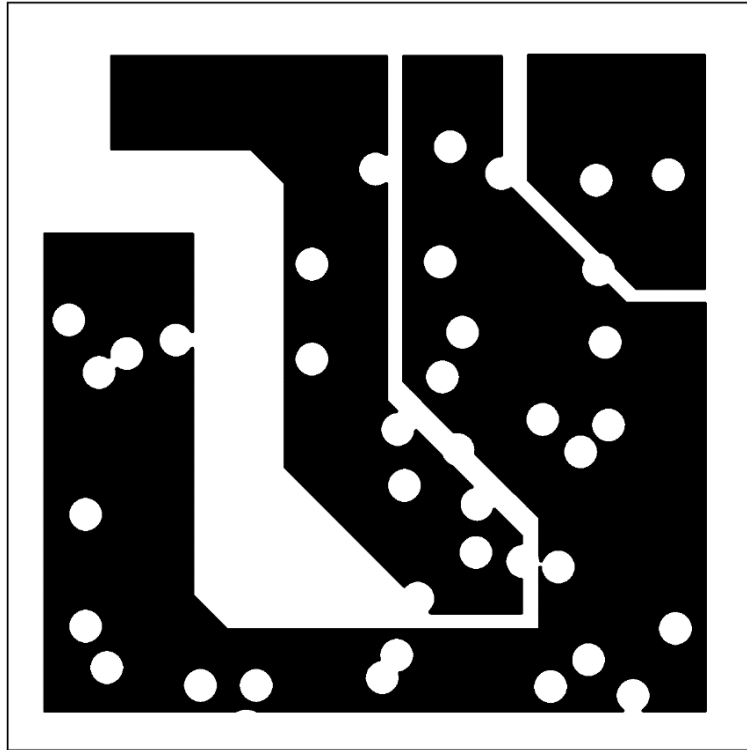
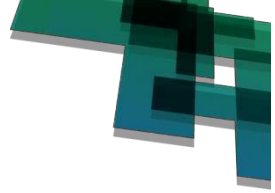

FIGURE 11 - INTERFACE ADAPTOR INNER LAYER 2 ROUTING

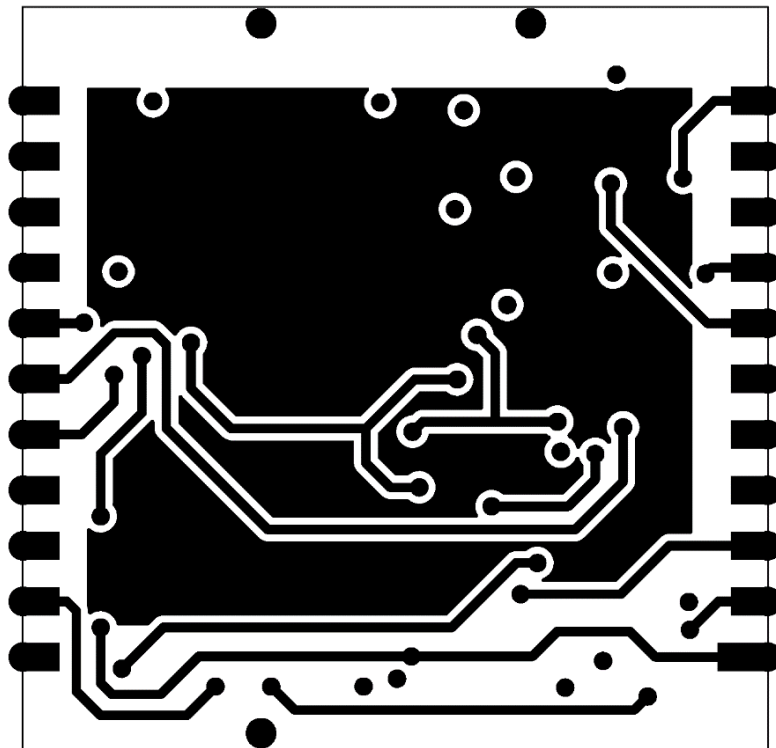

FIGURE 12 - INTERFACE ADAPTOR BOTTOM LAYER ROUTING



15. TTL-232R-3V3 USB-Serial CONVERTER CABLE*

The TTL-232R-3V3 is a USB to Serial converter cable that provides a simple way to connect devices with UART interface to PC.

The TTL-232R-3V3 uses an FTDI FT232RQ IC which is housed inside the USB Type 'A' connector and is terminated at the end of a 1.8 meter cable (6 ft.) with a 2.54mm (0.1) pitch header socket which provides an access to UART standard Transmit Data (TxD) and Receive Data (RxD). These lines are operating at 3.3V LVTTTL levels. Also brought out on the header are +5V and GND.



FIGURE 13 - PIN HEADER SOCKET BOTTOM VIEW

Pin Number	Name	Type	Colour	Description
1	GND	Power	Black	Ground supply pin
2	CTS	Input	Brown	Clear To Send input – not in use
3	VCC	Power	Red	+5V power source, USB specified
4	TXD	Output	Orange	Asynchronous Data output – GPS input
5	RXD	Input	Yellow	Asynchronous Data input – GPS output
6	RTS	Output	Green	Request To Send output – not in use

TABLE 5 - USB-SERIAL CONVERTER CABLE HEADER PIN-OUT

Parameter	Symbol	Test Conditions	Min	Typ	Max	Units
Power Supply Voltage	V_{CC}	Defined by USB V_{BUS}	4.25	5.0	5.25	V
Power Supply Current	I_o		-	-	75	mA
Output Voltage Low State	V_{OL}	$I_{OL} = 8mA$	0.3	0.4	0.6	V
Output Voltage High State	V_{OH}	$I_{OH} = -3mA$	2.2	2.8	3.2	V
Input Voltage State Switching Threshold	V_{IN}	Low \rightarrow High High \rightarrow Low	1.0	1.2	1.5	V
Input Voltage State Switching Hysteresis	V_{HYST}		20	25	30	mV
Operating Temperature	T_{AMB}		-40	+25	+85	$^{\circ}C$

TABLE 6 - USB-SERIAL CONVERTER CABLE OPERATING PARAMETERS

*Note: For more information refer to FTDI Ltd. TTL-232R TTL To USB Serial Converter Range Of Cables Datasheet, Document Reference No.: FT_000054



16. ORG9802 MINIATURE PASSIVE ANTENNA ASSEMBLY*

16.1 GENERAL

ORG9802 is a miniature antenna assembly, comprising four components:

1. Ceramic patch antenna element
2. Adaptor PCB
3. Coaxial cable
4. Connector

16.2 MECHANICAL SPECIFICATIONS

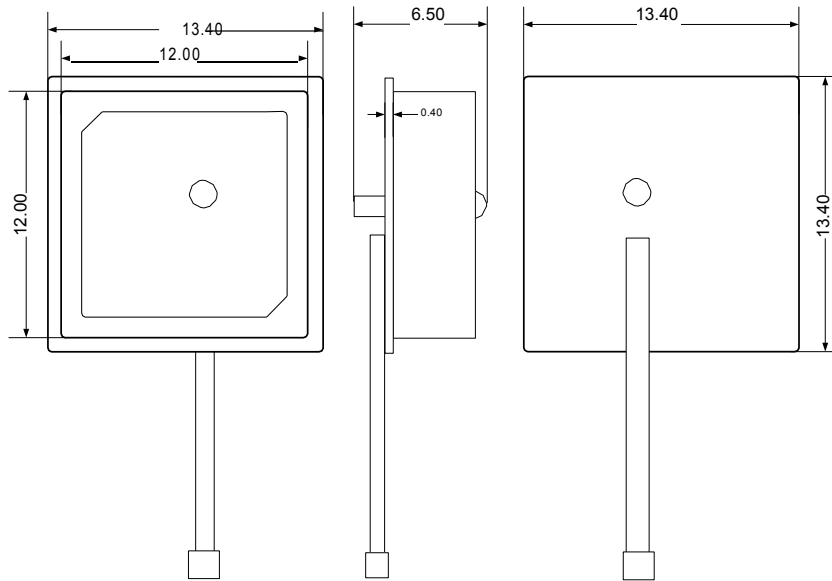

FIGURE 14 - ORG9802 MECHANICAL OUTLINE

Dimensions	Length	Width	Thickness	Weight	
	mm	13.4 ± 0.2	13.4 ± 0.2	6.5 ± 0.1	gr
inch	0.528 ± 0.008	0.528 ± 0.008	0.256 ± 0.004	oz	0.14

TABLE 7 - ORG9802 MECHANICAL SPECIFICATIONS

*Note: For more information refer to OriginGPS ORG9802 Patch Antenna Assembly Datasheet, Document number 300311



16.3 ELECTRICAL SPECIFICATIONS

Parameter	Value		Unit	Notes
Resonant Frequency (f_c)	GPS	1575 ± 2	MHz	13mm x 13mm GP
	GLONASS	1598 - 1606		
Return Loss (S_{11})	-10 (min)		dB	@ f_c
Bandwidth (BW)	10 (min)		MHz	@ $f(S_{11}=-9dB)$
VSWR	1.5 (max)			
Impedance (Z_A)	50		Ω	
Axial Ratio (AR)	5.0 (max)		dB	
Gain @ f_c	GPS	-0.3 (max.)	dBic	13mm x 13mm GP
	GLONASS	-3.5 (max.)		
Polarization	RHCP			
Temperature Factor (t_f)	0±20		ppm/°C	-40°C to +85°C

TABLE 8 - ORG9802 ELECTRICAL SPECIFICATIONS

TYPICALS11

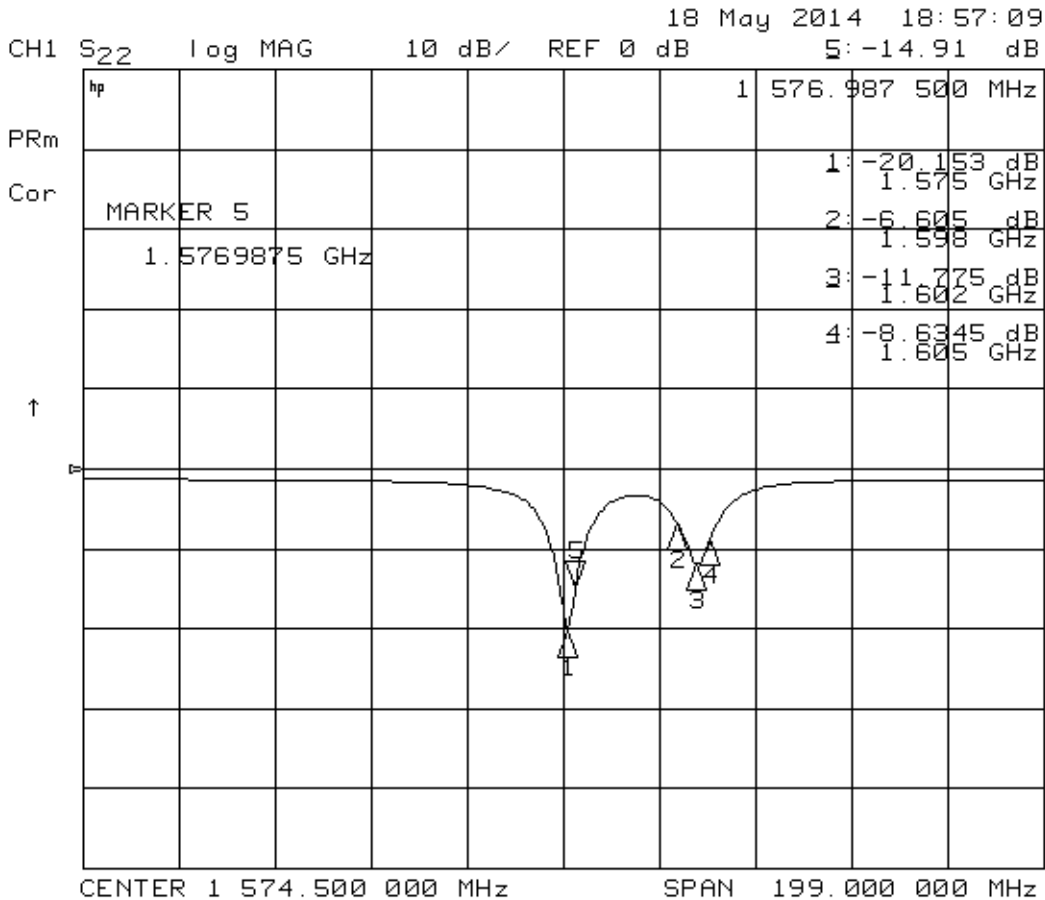
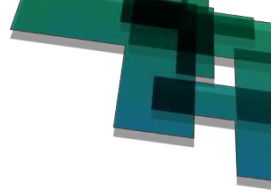

FIGURE 15 - ORG9802 S11 LOG MAGNITUDE



17. ORG9805 External Active Antenna*

17.1 DESCRIPTION

The ORG9805 External Active Antenna incorporates high-efficiency ceramic patch antenna element, high out-of-band rejection band-pass Surface Acoustic Wave (SAW) filter, low Noise Figure and high gain Low Noise Amplifier (LNA), enclosed in plastic case, with coaxial cable terminated by standard SMA-type plug. The ORG9805 Active Antenna with highest GNSS-band performance and notch filtering for out-of-band signals provides exceptional sensitivity, high selectivity and noise immunity. The ORG9805 Active Antenna is built of highest quality materials and components. The ORG9805 Active Antenna is the perfect match to the OriginGPS GNSS receiver modules.

17.2 FEATURES

- Antenna element with high efficiency for excellent coverage of GNSS satellites
- SAW filter for rejection of out-of-band signals
- LNA with low Noise Figure and high gain for high sensitivity
- Plastic case with magnetic base
- RG-174 flexible coaxial cable of 5m length
- SMA-type gold plated plug

17.3 BENEFITS

- High performance
- Compact size
- Easy integration

17.4 BLOCK DIAGRAM

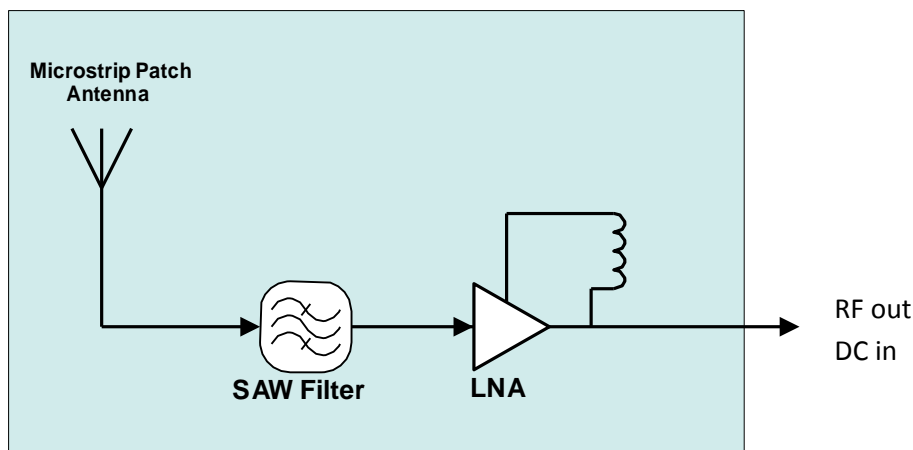

FIGURE 16 - ORG9805 BLOCK DIAGRAM

*Note: For more information refer to OriginGPS ORG9805 External Active Antenna Datasheet, Document number 160112



17.5 ELECTRICAL SPECIFICATIONS

Parameter	Value	Unit	Notes
Frequency Range	1575.43±5 1610±8	MHz	
Bandwidth (BW)	10	MHz	For GPS
	20	MHz	For GLONASS
Peak Gain	5 (min)	dBic	@ f _c , 70mm x 70mm GP
Gain Coverage	-4 (min)	dBic	@ f _c , -90°<θ< 90° (over 75% volume)
Axial Ratio (AR)	2.0 (max)	dB	
Polarization	R.H.C.P		
Power Handling	30	dBm	out of band signal
LNA Gain	30 (typ)	dB	without cable loss
LNA Noise Figure	1.5 (max)	dB	
DC Voltage	3 - 5	V	supplied via coaxial cable
DC Current	11.5 (typ)	mA	@3.0V
Cable Insertion Loss	1.2 (typ)	dB/m	
VSWR	2.0 (max)		@output
Impedance	50 ± 1	Ω	@output

TABLE 9 - ORG9805 ELECTRICAL SPECIFICATIONS

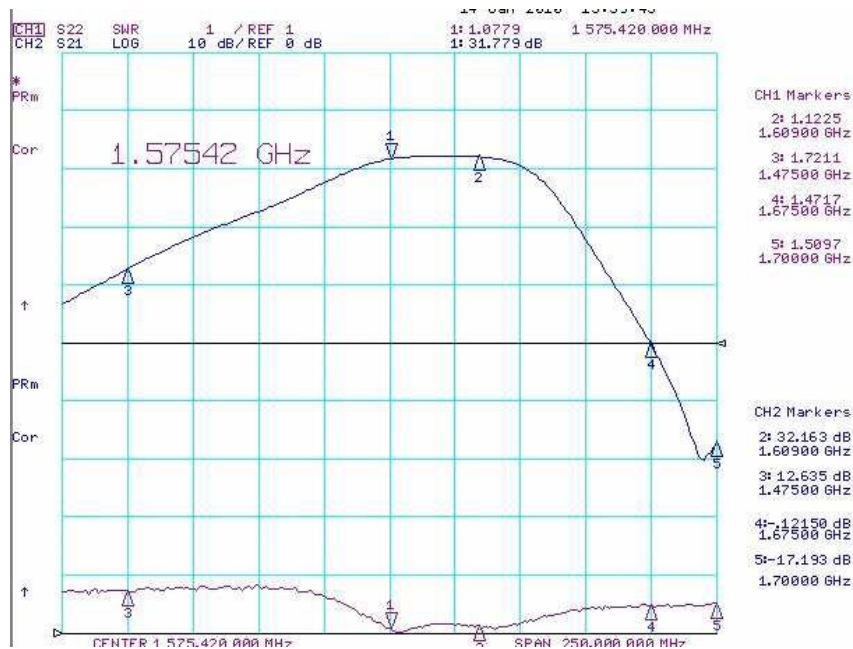

FIGURE 17 - ORG9805 S11 LOG MAGNITUDE



17.6 MECHANICAL SPECIFICATIONS

Parameter	Value	Unit	Notes
Size (L x W x H)	48.6 x 39.2 x 15.2	mm	tolerance: $\pm 0.5\text{mm}$
Weight	106 (approx.)	g	including cable
Housing	PC		
Color	Black		
Mounting	Magnetic base		
Orientation	Horizontal surface		
Cable Type	RG-174		diameter: $2.7 \pm 0.1\text{mm}$
Cable Length	5	m	
Connector Type	SMA Plug		Gold plated

TABLE 10 - ORG9805 MECHANICAL SPECIFICATIONS

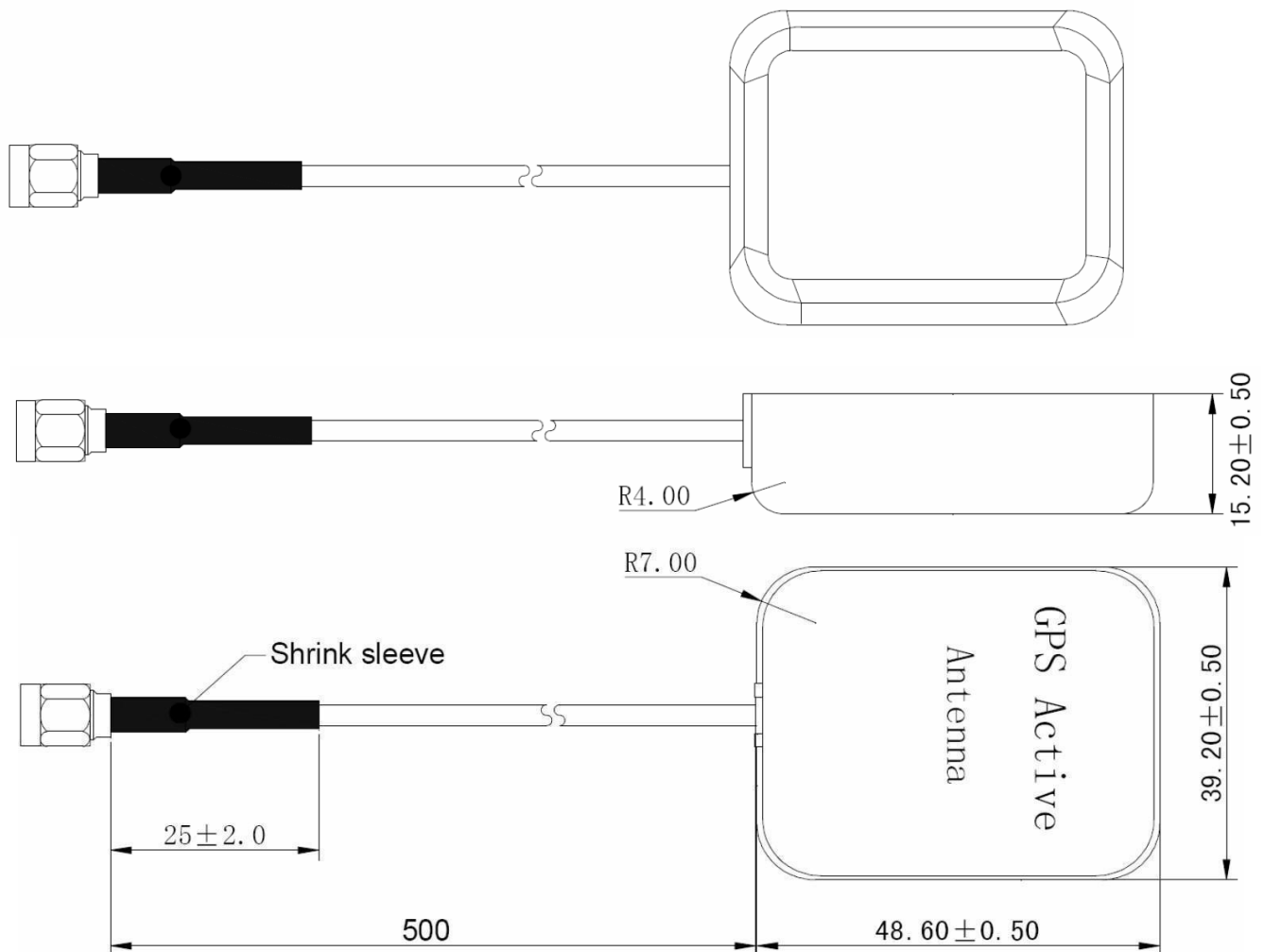

FIGURE 18 - ORG9805 MECHANICAL OUTLINE



18. I-PEX MHFIII TO SMA-TYPE COAXIAL CABLE ADAPTOR

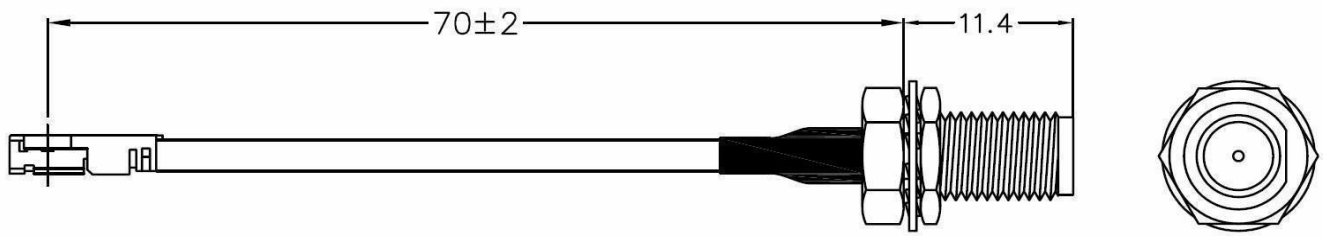

FIGURE 19 - I-PEX MHFIII TO SMA-TYPE ADAPTOR MECHANICAL OUTLINE