



San Technology, Inc.

**SPECIFICATION
FOR
LCD Module**

Customer P/N:

Santek P/N: ST0154A1W-RSLW-C

DOC. Revision: RS02

Customer Approval:

--

	SIGNATURE	DATE
PREPARED BY	Aaron Lu	2020-04-16
CHECKED BY	Andy Song	2020-4-17
APPROVED BY	<i>Natty Lee</i>	2020.Apr.17

Document Revision History

Version	Revise Date	Description	Changed by
RS01	2020-01-13	First issue	Aaron Lu
RS02	2020-04-16	Add package drawing.(Page 17)	Aaron Lu

Table of Contents

1. GENERAL SPECIFICATION.....4

2. BLOCK DIAGRAM5

3. MECHANICAL DRAWING6

4. PIN DESCRIPTION7

5. ABSOLUTE MAXIMUM RATINGS.....8

6. DC CHARACTERISTICS8

7. BACKLIGHT SPECIFICATION.....8

8. TIMING CHARACTERISTICS.....9

9. OPTICAL CHARACTERISTICS13

10. RELIABILITY TESTS16

11. PACKAGE DRAWING.....17

12. INSPECTION CRITERIA18

13. SUGGESTIONS FOR USING LCD MODULES.....22

Santek | CONFIDENTIAL

1. General Specification

1.1 Description

ST0154A1W-RSLW-C is a color active matrix TFT-LCD Model using amorphous silicon TFT's (Thin Film Transistors) as an active switching devices. It is a transmissive type display operating in the normal black. This TFT-LCD has a 1.54 inch diagonally measured active area with 240 horizontal by 240 vertical pixel array. Each pixel is divided into Red, Green, Blue dots which are arranged in vertical stripe and this panel can display 262K colors.

1.2 General Specification

Item	Specification	Units
LCD Type	1.54	inch
Resolution	240*240	dots
Color Filter Array	RGB Vertical Stripe	-
Display Mode	Normally Black, Transmissive	-
Viewing Direction	All direction,80/80/80/80	-
Drive IC	ST7789V	-
Interface	4-line serial interface I ² C,IM[3:0]=0110	-
Module Size	31.52(W) x 35(H) x 2.1(D)	mm
Active Area	27.72(W) x 27.72(H)	mm
Pixel Pitch	0.1155(W) x 0.1155(H)	mm
Operating Temperature	-20~70	°C
Storage Temperature	-30~80	°C

2. Block Diagram

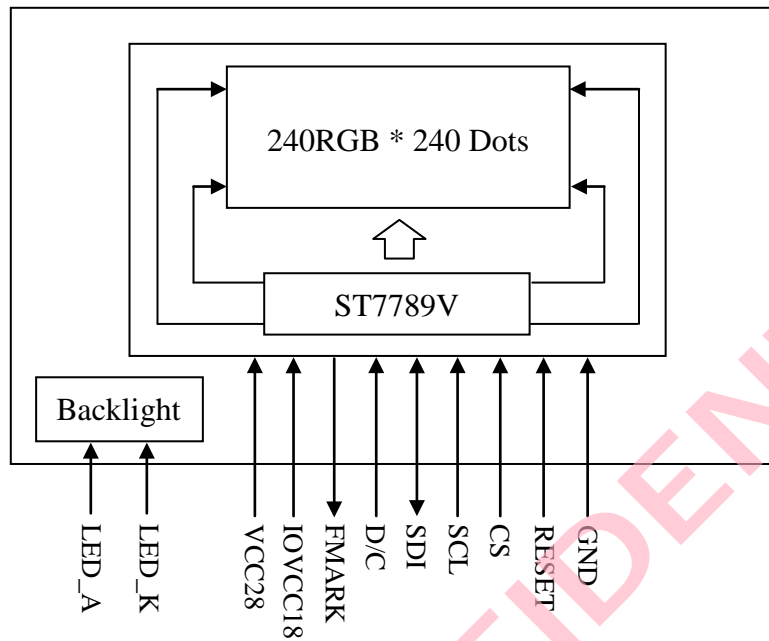

3. Mechanical Drawing

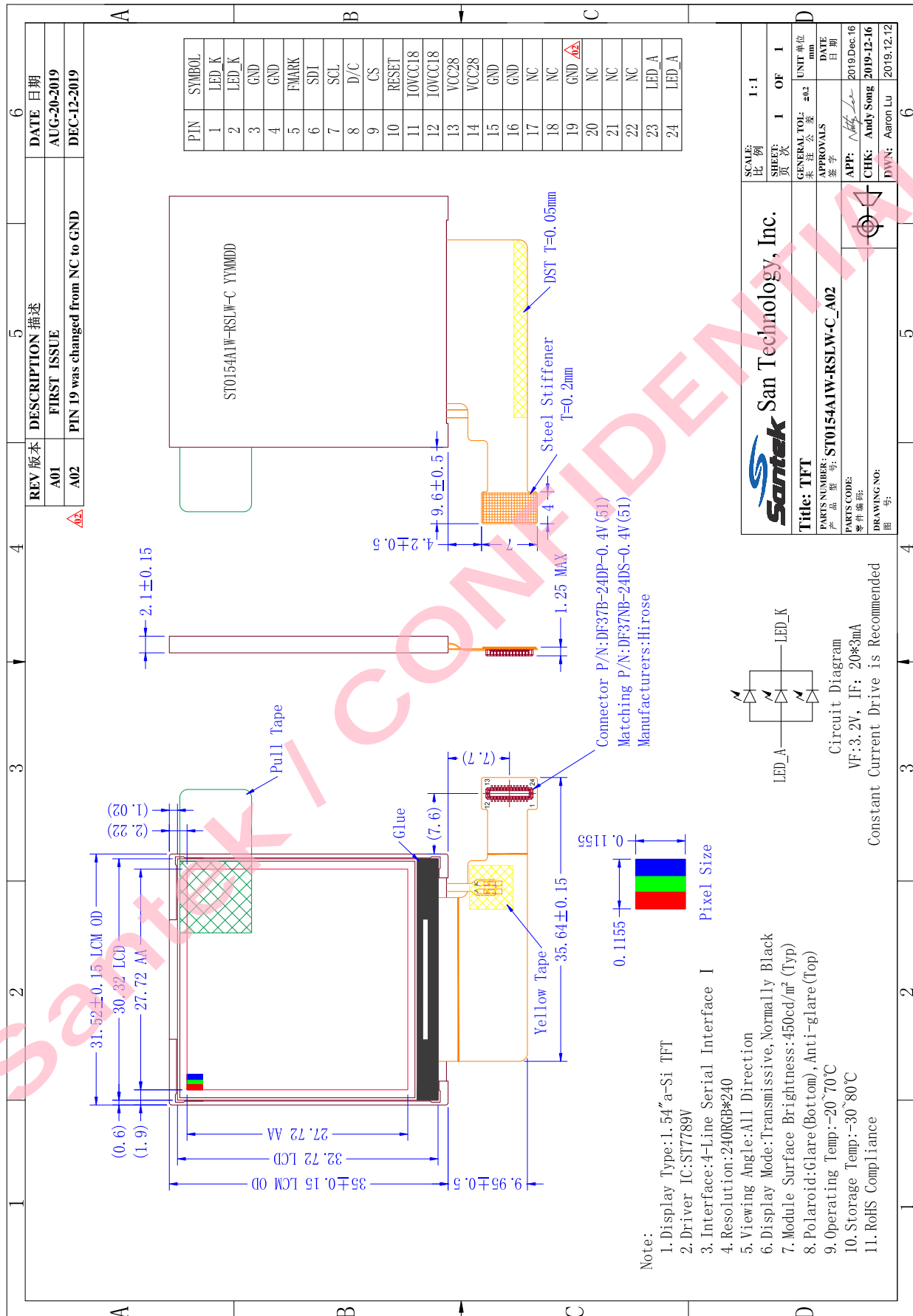

4. Pin Description

Pin	Symbol	Function Descriptions
1	LED_K	Power supply for backlight(Cathode).
2	LED_K	Power supply for backlight(Cathode).
3	GND	System ground.
4	GND	System ground.
5	FMARK	Tearing effect signal is used to synchronize MCU to frame memory.
6	SDI	Serial input/output data.
7	SCL	Clock signal.
8	D/C	Display data/command selection pin. (H:data,L:command)
9	CS	Chip selection pin. (H:disable,L:enable)
10	RESET	This signal will reset the device. (Signal is active low)
11	IOVCC18	Power supply for I/O system.
12	IOVCC18	Power supply for I/O system.
13	VCC28	Power supply for analog, digital system and booster circuit.
14	VCC28	Power supply for analog, digital system and booster circuit.
15	GND	System ground.
16	GND	System ground.
17	NC	No connect.
18	NC	No connect.
19	GND	System ground.
20	NC	No connect.
21	NC	No connect.
22	NC	No connect.
23	LED_A	Power supply for backlight(Anode).
24	LED_A	Power supply for backlight(Anode).

Note: Interface: 4-line serial interface I²C, IM[3:0]=0110.

5. Absolute Maximum Ratings

Item	Symbol	Rating	Unit
Supply Voltage	VDD(VCC28)	-0.3 ~ +4.6	V
Supply Voltage (Logic)	VDDI(IOVCC18)	-0.3 ~ +4.6	V
Operating Temperature Range	TOPR	-20 ~ +70	°C
Storage Temperature Range	TSTG	-30 ~ +80	°C

Note: If one of the above items is exceeded its maximum limitation momentarily, the quality of the product may be degraded. Absolute maximum limitation, therefore, specify the values exceeding which the product may be physically damaged. Be sure to use the product within the recommend range.

6. DC Characteristics

Item	Symbol	Min	Typ	Max	Unit
System Voltage	VDD(VCC28)	2.4	2.8	3.3	V
Interface Operation Voltage	VDDI(IOVCC18)	1.65	1.8	3.3	V

7. Backlight Specification

Item	Symbol	Min	Typ	Max	Unit
Forward Current	I_F	-	60	-	mA
Forward Voltage	V_F	3.0	3.2	3.4	V
Backlight Power Consumption	W_{BL}	-	0.192	-	W
LED Lifetime		-	25000	-	hrs

Note1: Each LED: I_F : 20mA, V_F : $3.2 \pm 0.2V$.

Note2: Optical performance should be evaluated at $T_a = 25^\circ C$ only.

Note3: If LED is driven by high current, high ambient temperature & humidity condition.

The life time of LED will be reduced.

Note4: LED Lifetime: Operating life means brightness goes down to 50% initial brightness.

Typical operating life time is estimated data.

Note5: Constant current drive is recommended.

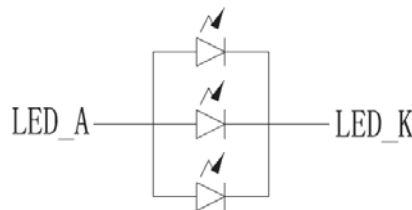

Backlight Circuit Diagram

8. Timing Characteristics

8.1 Serial Interface

IM[3:0]=0110

IM3	IM2	IM1	IM0	Interface	Read back selection
0	1	0	1	3-line serial interface I	Via the read instruction (8-bit, 24-bit and 32-bit read parameter)
0	1	1	0	4-line serial interface I	
1	1	0	1	3-line serial interface II	
1	1	1	0	4-line serial interface II	

Table 13 Selection of serial interface

The serial interface is either 3-lines/9-bits or 4-lines/8-bits bi-directional interface for communication between the micro controller and the LCD driver. The 3-lines serial interface use: CSX (chip enable), SCL (serial clock) and SDA (serial data input/output), and the 4-lines serial interface use: CSX (chip enable), D/CX (data/ command flag), SCL (serial clock) and SDA (serial data input/output). Serial clock (SCL) is used for interface with MCU only, so it can be stopped when no communication is necessary.

8.1.1 Pin Description

4-line serial interface I

Pin Name	Description
CSX	Chip selection signal
WRX	Data is regarded as a command when WRX is low Data is regarded as a parameter or data when WRX is high
DCX	Clock signal
SDA	Serial input/output data

8.1.2 Command Write Mode

The write mode of the interface means the micro controller writes commands and data to the LCD driver. 3-lines serial data packet contains a control bit D/CX and a transmission byte. In 4-lines serial interface, data packet contains just transmission byte and control bit D/CX is transferred by the D/CX pin. If D/CX is "low", the transmission byte is interpreted as a command byte. If D/CX is "high", the transmission byte is stored in the display data RAM (memory write command), or command register as parameter.

Any instruction can be sent in any order to the driver. The MSB is transmitted first. The serial interface is initialized when CSX is high. In this state, SCL clock pulse or SDA data have no effect. A falling edge on CSX enables the serial interface and indicates the start of data transmission.

4-line serial data stream format: Transmission byte (TB) may be command or data

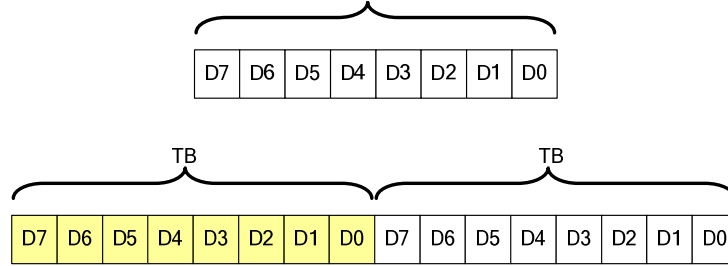

Figure 12 Serial interface data stream format

When CSX is “high”, SCL clock is ignored. During the high period of CSX the serial interface is initialized. At the falling edge of CSX, SCL can be high or low. SDA is sampled at the rising edge of SCL. D/CX indicates whether the byte is command (D/CX=’0’) or parameter/RAM data (D/CX=’1’). D/CX is sampled when first rising edge of SCL (3-line serial interface) or 8th rising edge of SCL (4-line serial interface). If CSX stays low after the last bit of command/data byte, the serial interface expects the D/CX bit (3-line serial interface) or D7 (4-line serial interface) of the next byte at the next rising edge of SCL..

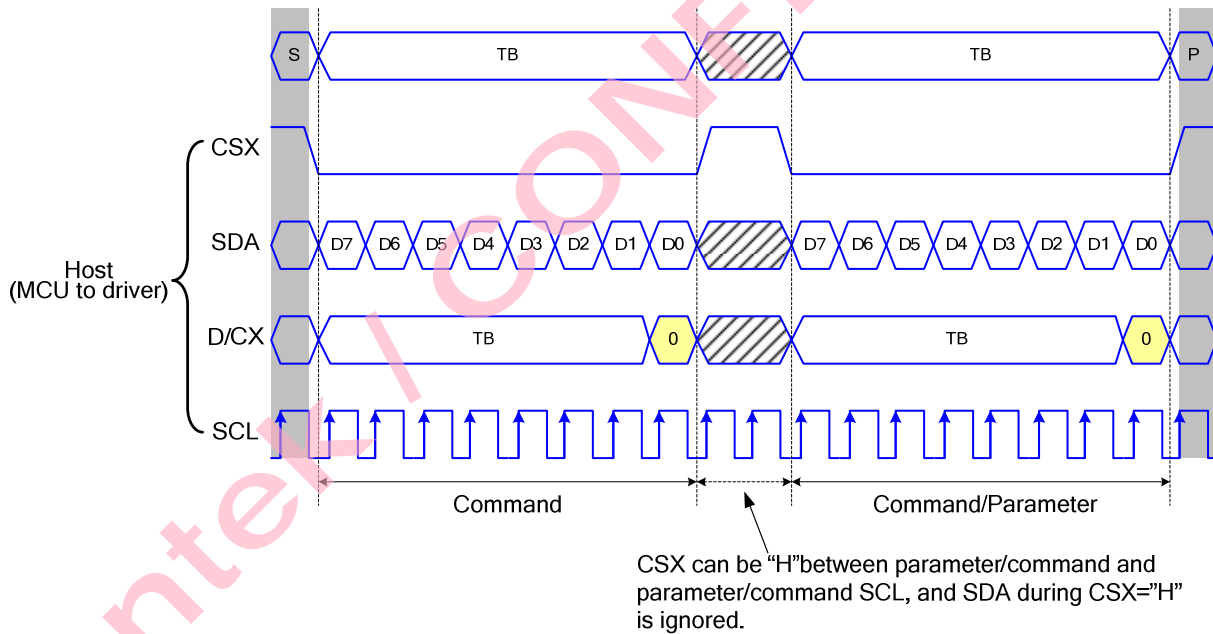

Figure 14 4-line serial interface write protocol (write to register with control bit in transmission)

8.2 Serial Interface Characteristics (4-line serial)

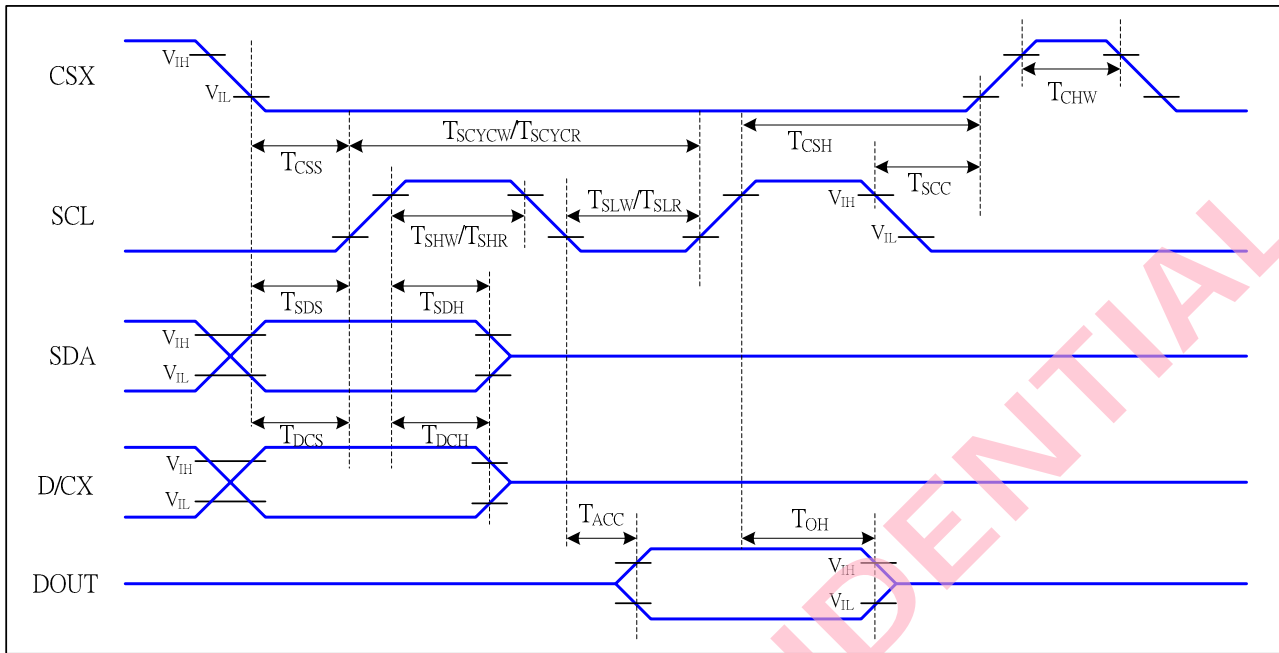

Figure 5 4-line serial Interface Timing Characteristics

VDDI=1.65 to 3.3V, VDD=2.4 to 3.3V, AGND=DGND=0V, Ta=25°C

Signal	Symbol	Parameter	MIN	MAX	Unit	Description
CSX	T _{CSS}	Chip select setup time (write)	15		ns	
	T _{CSH}	Chip select hold time (write)	15		ns	
	T _{CSS}	Chip select setup time (read)	60		ns	
	T _{SCC}	Chip select hold time (read)	65		ns	
	T _{CHW}	Chip select "H" pulse width	40		ns	
SCL	T _{SCYCW}	Serial clock cycle (Write)	66		ns	-write command & data ram
	T _{SHW}	SCL "H" pulse width (Write)	15		ns	
	T _{SLW}	SCL "L" pulse width (Write)	15		ns	
	T _{SCYCR}	Serial clock cycle (Read)	150		ns	-read command & data ram
	T _{SHR}	SCL "H" pulse width (Read)	60		ns	
	T _{SLR}	SCL "L" pulse width (Read)	60		ns	
D/CX	T _{DCS}	D/CX setup time	10		ns	
	T _{DCH}	D/CX hold time	10		ns	
SDA (DIN)	T _{SDS}	Data setup time	10		ns	
	T _{SDH}	Data hold time	10		ns	
DOUT	T _{ACC}	Access time	10	50	ns	For maximum CL=30pF
	T _{OH}	Output disable time	15	50	ns	For minimum CL=8pF

Table 6 4-line serial Interface Characteristics

Note : The rising time and falling time (Tr, Tf) of input signal are specified at 15 ns or less. Logic high and low levels are specified as 30% and 70% of VDDI for Input signals.

8.3 Reset Timing

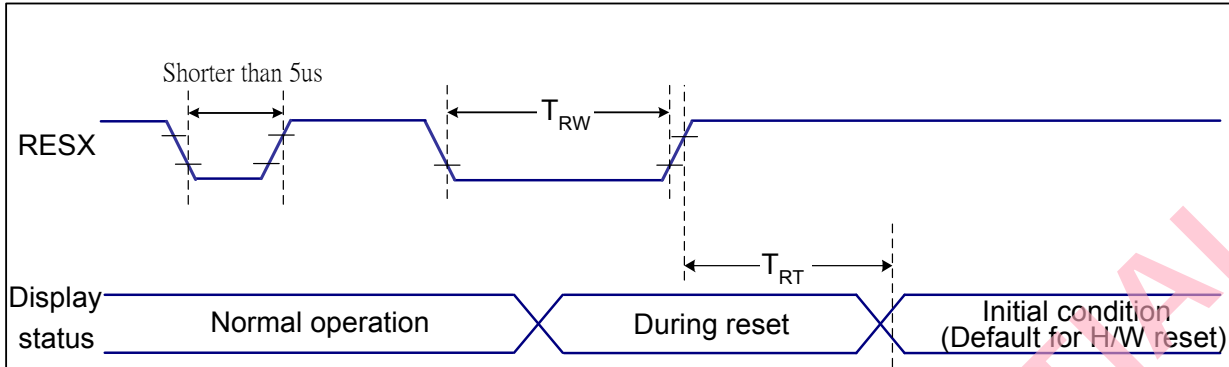

Figure 7 Reset Timing

VDDI=1.65 to 3.3V, VDD=2.4 to 3.3V, AGND=DGND=0V, Ta=25°C

Related Pins	Symbol	Parameter	MIN	MAX	Unit
RESX	TRW	Reset pulse duration	10	-	us
	TRT	Reset cancel	-	5 (Note 1, 5)	ms
				120 (Note 1, 6, 7)	ms

Table 9 Reset Timing

Notes:

- The reset cancel includes also required time for loading ID bytes, VCOM setting and other settings from NVM (or similar device) to registers. This loading is done every time when there is HW reset cancel time (tRT) within 5 ms after a rising edge of RESX.
- Spike due to an electrostatic discharge on RESX line does not cause irregular system reset according to the table below:

RESX Pulse	Action
Shorter than 5us	Reset Rejected
Longer than 9us	Reset
Between 5us and 9us	Reset starts

3. During the Resetting period, the display will be blanked (The display is entering blanking sequence, which maximum time is 120 ms, when Reset Starts in Sleep Out –mode. The display remains the blank state in Sleep In –mode.) and then return to Default condition for Hardware Reset.

4. Spike Rejection also applies during a valid reset pulse as shown below:

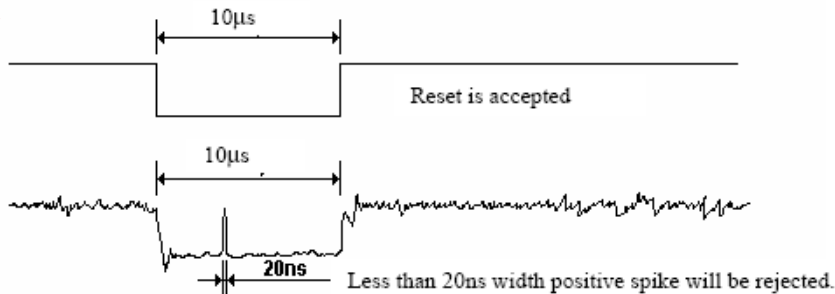

5. When Reset applied during Sleep In Mode.

6. When Reset applied during Sleep Out Mode.

7. It is necessary to wait 5msec after releasing RESX before sending commands. Also Sleep Out command cannot be sent for 120msec.

9. Optical Characteristics

Item	Symbol	Specifications			Unit	Note	
		Min	Typ	Max			
Contrast Ratio	Cr($\Theta=0^\circ$)	300	500	-	-	Note1	
Response Time(25°C)	Tr+Tf($\Theta=0^\circ$)	-	30	35	ms	Note2	
Viewing Angle (Cr\geq10)	Θ_R	$\phi=0^\circ$	75	80	-	deg Note3	
	Θ_T	$\phi=90^\circ$	75	80	-		
	Θ_L	$\phi=180^\circ$	75	80	-		
	Θ_B	$\phi=270^\circ$	75	80	-		
Chromaticity ($\Theta=0^\circ$)	White	x	0.2320	0.2820	0.3320	-	Note4
		y	0.2601	0.3101	0.3601		
	Red	x	0.5383	0.5883	0.6383		
		y	0.2957	0.3457	0.3957		
	Green	x	0.2572	0.3072	0.3572		
		y	0.5262	0.5762	0.6262		
	Blue	x	0.0977	0.1477	0.1977		
		y	0.0504	0.1004	0.1504		
Luminance	$\Theta=0^\circ$	360	450	-	cd/m ²	Note5	
Luminance Uniformity	-	70	85	-	%	Note6	
Color Gamut(NTSC)	-	-	50	-	%	-	

Note 1: Definition of contrast ratio

$$\text{Contrast ratio (CR)} = \frac{\text{Luminance measured when LCD on the "White" state}}{\text{Luminance measured when LCD on the "Black" state}}$$

Note 2: Definition of response time

The response time is defined as the LCD optical switching time interval between "White" state and "Black" state. Rise time (T_{on}) is the time between photo detector output intensity changed from 90% to 10%, and fall time (T_{off}) is the time between photo detector output intensity changed from 10% to 90%.

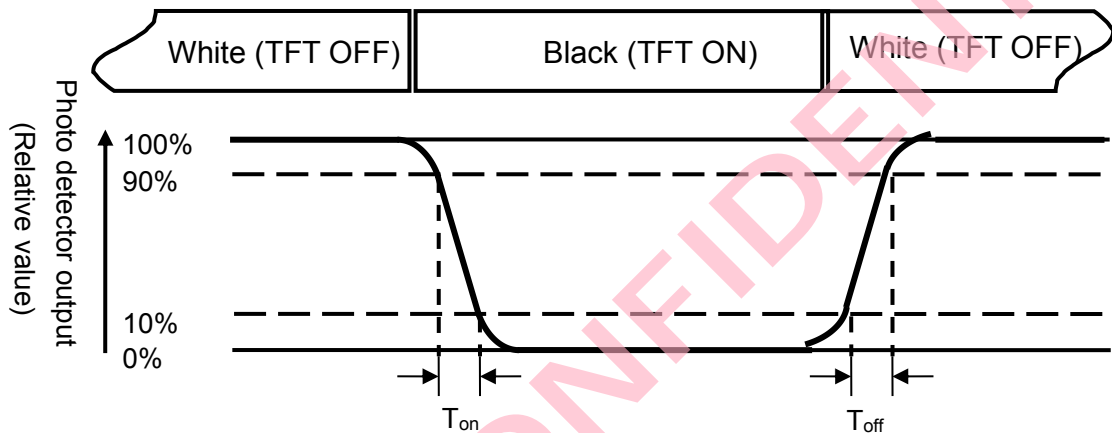

Note 3: Definition of viewing angle range

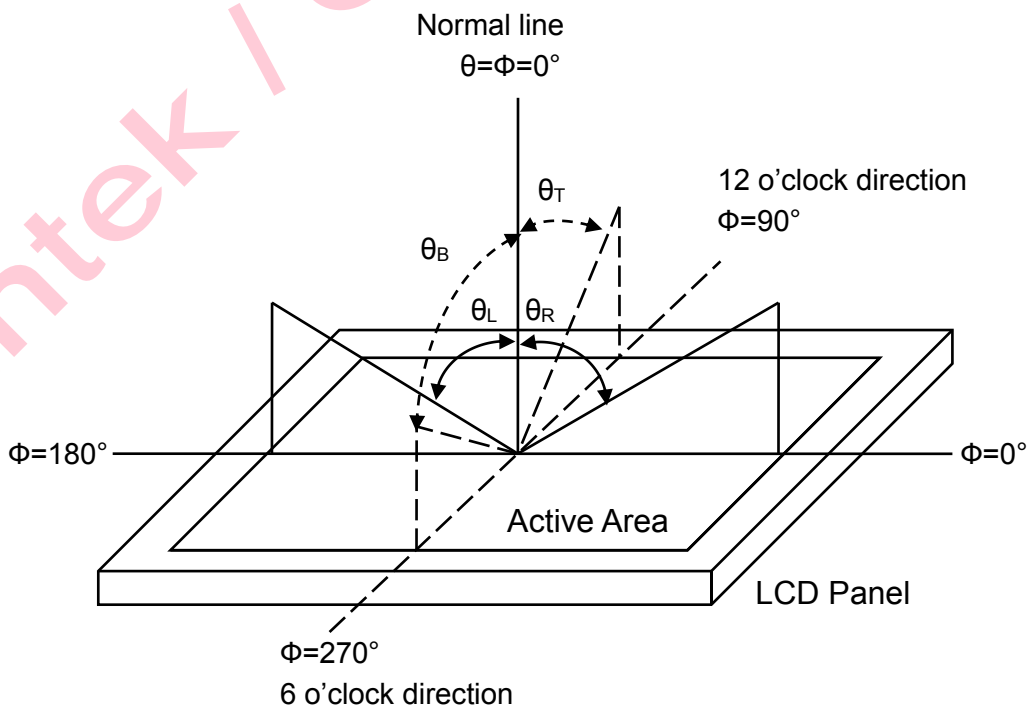

Note 4: Definition of color chromaticity (CIE1931)

Color coordinates measured at the center point of LCD when panel is driven at “White”, “Red”, “Green” and “Blue” state respectively.

Note 5: Definition of luminance

Measured at the center area of the panel when LCD panel is driven at “white” state.

Note 6: Definition of luminance uniformity

To test for uniformity, the tested area is divided into 5 spot. The measurement spot is placed at the center of each circle as below.

$$\text{Luminance Uniformity } (U_L) = \frac{L_{\min}}{L_{\max}}$$

L-----Active area length W----- Active area width

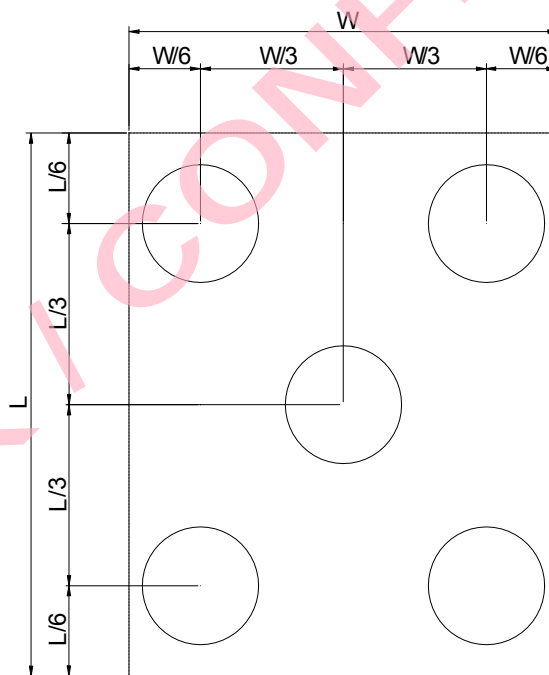

Fig. 5 Definition of luminance uniformity

L_{\min} : The measured minimum luminance of all measurement position.

L_{\max} : The measured maximum luminance of all measurement position.

10. Reliability Tests

No.	Item	Condition	Criterion
1	High Temperature Storage	80±3℃,96Hours	No defects in display and operational functions
2	Low Temperature Storage	-30±3℃,96Hours	
3	High Temperature Operating	70±3℃,96Hours	
4	Low Temperature Operating	-20±3℃,96Hours	
5	Damp Proof Test(Storage)	60±3℃,90±3%RH,96Hours	
6	Temperature Shock	-30℃(30mins)→80℃(30mins),10Cycle	

Remark:

- 1.The Test samples should be applied to only one test item.
2. Sample for each test item is 3pcs.
3. For Damp Proof Test, Pure water(Resistance>10MΩ)should be used.
4. The samples must be free from defect before test, must be restored at room condition at least for 2 hours storage at room temperature after reliability test before any inspection.
5. Failure Judgment Criterion: Basic Specification Electrical Characteristic, Mechanical Characteristic, Optical Characteristic.

11. Package Drawing

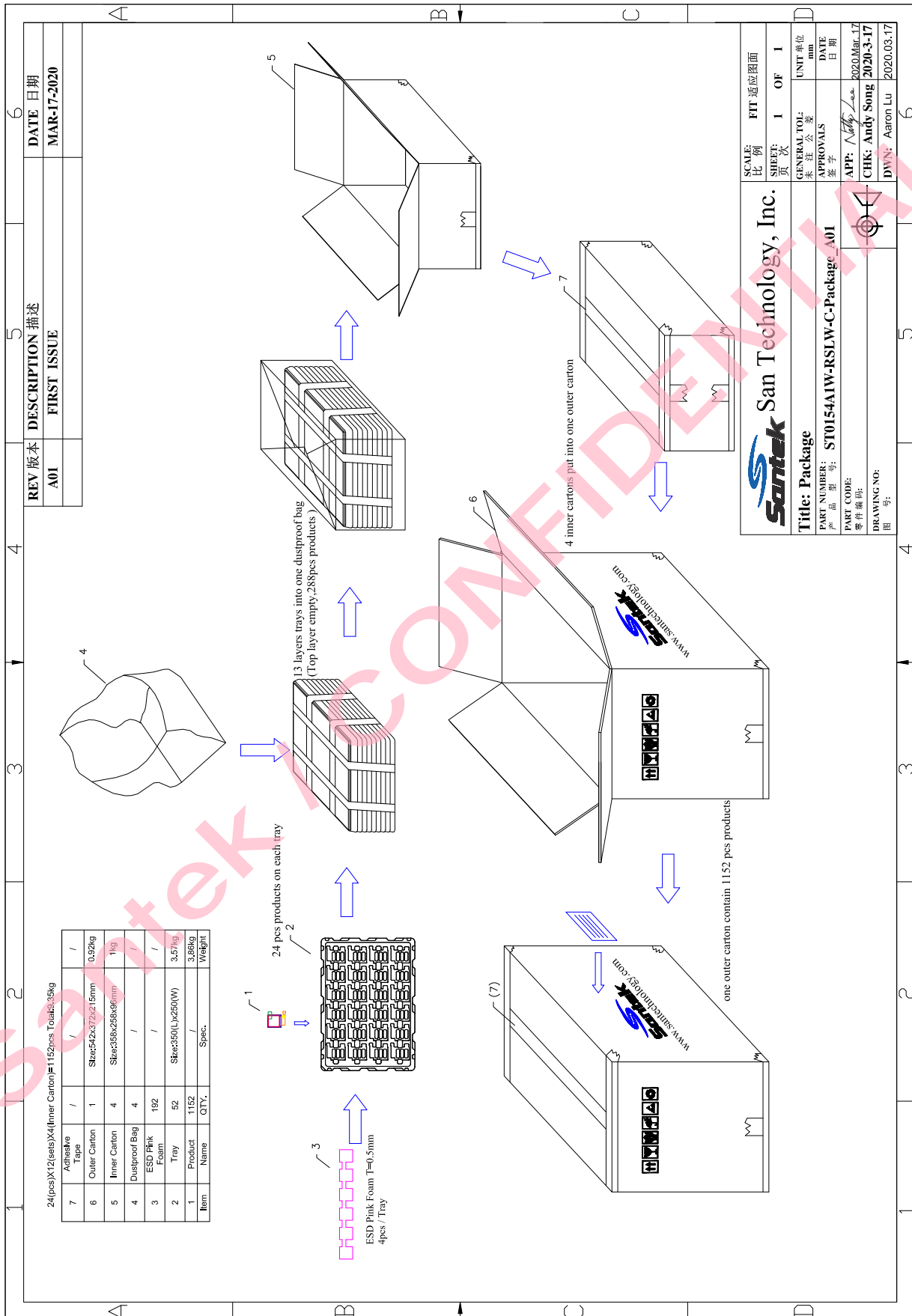

12. Inspection Criteria

12.1 Scope

The incoming inspection standards shall be applied to TFT –LCD Modules(hereinafter called "Modules") that supplied by San Technology,Inc.

12.2 Incoming Inspection

The customer shall inspect the modules within thirth calendar days of the delivery date (the “inspection period) a t its own cost. The result of the inspection (a cceptance or rejection)s hall be recorded in writing,and a copy of this writing will be promptly sent to the seller, If the results of the inspecting from buyer does not send to the seller within thirth calendar days of the delivery date. The modules shall be regards as acceptance. Should the customer fail to notify the seller within the inspection period, the buyers right to reject the modules. Shall be lapsed and the modules shall be deemed to have been accepted by the buyer.

12.3 Inspection Sampling Method

12.3.1. Lot size: Quantity per shipment lot per model

12.3.2. Sampling type: Normal inspection, Single sampling

12.3.3. Inspection level: II

12.3.4. Sampling table: GB/T2828.1-2003

12.3.5. Acceptable quality level (AQL)

Major defect: AQL=0.65

Minor defect: AQL=1.00

12.4 Inspection Conditions

12.4.1 Ambient conditions:

a. Temperature: Room temperature $25\pm 5^{\circ}\text{C}$

b. Humidity: $(60\pm 10)\% \text{RH}$

c. Illumination: Single fluorescent lamp non-directive (300 to 700 Lux)

12.4.2 Viewing distance

The distance between the LCD and the inspector’s eyes shall be at least 35~40cm.

12.4.3 Viewing Angle

U/D: $45^{\circ}/45^{\circ}$, L/R: $45^{\circ}/45^{\circ}$

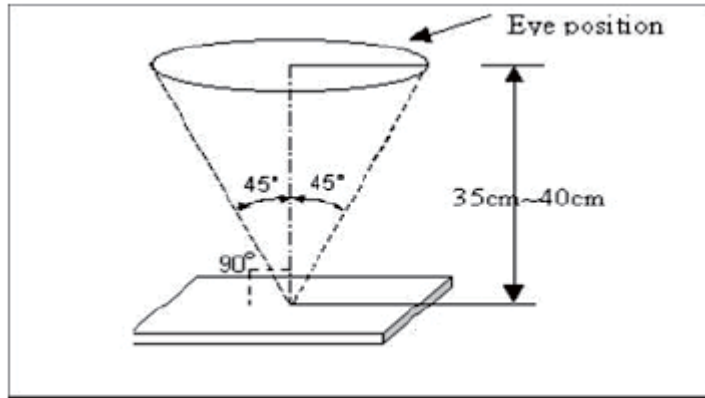

area definition

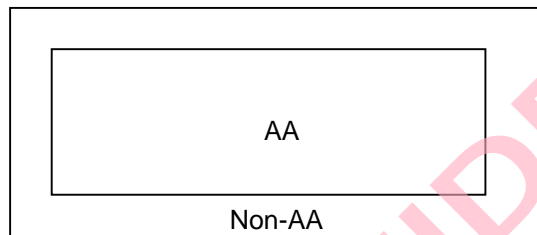

LCD inspection area

AA:Active Area

Non-AA:Non Active Area

12.5 Define Defect Level

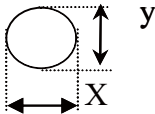
No	Item	Criterion for defects	Defect type														
1	Black/white spot defect (in displaying)	<p>black/white spot definition</p> $\Phi = (x+y)/2$  <p>1. black/white spot defect</p> <table border="1"> <thead> <tr> <th rowspan="2">area size (mm)</th> <th colspan="2">Acceptable number</th> </tr> <tr> <th>AA</th> <th>Non-AA</th> </tr> </thead> <tbody> <tr> <td>$\Phi \leq 0.1$</td> <td>ignore</td> <td rowspan="4">ignore</td> </tr> <tr> <td>$0.1 < \Phi \leq 0.25$</td> <td>3</td> </tr> <tr> <td>$0.25 < \Phi \leq 0.30$</td> <td>2</td> </tr> <tr> <td>$\Phi > 0.30$</td> <td>0</td> </tr> </tbody> </table>	area size (mm)	Acceptable number		AA	Non-AA	$\Phi \leq 0.1$	ignore	ignore	$0.1 < \Phi \leq 0.25$	3	$0.25 < \Phi \leq 0.30$	2	$\Phi > 0.30$	0	Minor
area size (mm)	Acceptable number																
	AA	Non-AA															
$\Phi \leq 0.1$	ignore	ignore															
$0.1 < \Phi \leq 0.25$	3																
$0.25 < \Phi \leq 0.30$	2																
$\Phi > 0.30$	0																

2	Black/white line defect (in displaying)	<p>1. black/white line defect</p> <table border="1"> <thead> <tr> <th colspan="2">size (mm)</th> <th colspan="2">Acceptable number</th> </tr> <tr> <th rowspan="2">L(length)</th> <th rowspan="2">W(width)</th> <th colspan="2">area</th> </tr> <tr> <th>AA</th> <th>Non-AA</th> </tr> </thead> <tbody> <tr> <td>ignore</td> <td>$0.03 < W \leq 0.04$</td> <td>ignore</td> <td rowspan="4">ignore</td> </tr> <tr> <td>$5.0 < L \leq 10$</td> <td>$0.05 < W \leq 0.07$</td> <td>4</td> </tr> <tr> <td>$L \leq 1.0$</td> <td>$0.07 < W \leq 0.1$</td> <td>1</td> </tr> <tr> <td>-</td> <td>$W > 0.1$</td> <td>Treat as dot</td> </tr> </tbody> </table>	size (mm)		Acceptable number		L(length)	W(width)	area		AA	Non-AA	ignore	$0.03 < W \leq 0.04$	ignore	ignore	$5.0 < L \leq 10$	$0.05 < W \leq 0.07$	4	$L \leq 1.0$	$0.07 < W \leq 0.1$	1	-	$W > 0.1$	Treat as dot	Minor			
size (mm)		Acceptable number																											
L(length)	W(width)	area																											
		AA	Non-AA																										
ignore	$0.03 < W \leq 0.04$	ignore	ignore																										
$5.0 < L \leq 10$	$0.05 < W \leq 0.07$	4																											
$L \leq 1.0$	$0.07 < W \leq 0.1$	1																											
-	$W > 0.1$	Treat as dot																											
3	Blemish & foreign matters	<p>1. Dot</p> <table border="1"> <thead> <tr> <th rowspan="2">size(mm)</th> <th colspan="2">Acceptable number</th> </tr> <tr> <th>AA</th> <th>Non-AA</th> </tr> </thead> <tbody> <tr> <td>$\Phi \leq 0.1$</td> <td>ignore</td> <td rowspan="4">ignore</td> </tr> <tr> <td>$0.10 < \Phi \leq 0.25$</td> <td>2</td> </tr> <tr> <td>$0.25 < \Phi \leq 0.30$</td> <td>1</td> </tr> <tr> <td>$\Phi > 0.30$</td> <td>0</td> </tr> </tbody> </table> <p>2. Blemish</p> <table border="1"> <thead> <tr> <th rowspan="2">size(mm)</th> <th colspan="2">Acceptable number</th> </tr> <tr> <th>AA</th> <th>Non-AA</th> </tr> </thead> <tbody> <tr> <td>$\Phi \leq 0.1$</td> <td>ignore</td> <td rowspan="3">ignore</td> </tr> <tr> <td>$0.10 < \Phi \leq 0.25$</td> <td>1</td> </tr> <tr> <td>$\Phi > 0.30$</td> <td>0</td> </tr> </tbody> </table>	size(mm)	Acceptable number		AA	Non-AA	$\Phi \leq 0.1$	ignore	ignore	$0.10 < \Phi \leq 0.25$	2	$0.25 < \Phi \leq 0.30$	1	$\Phi > 0.30$	0	size(mm)	Acceptable number		AA	Non-AA	$\Phi \leq 0.1$	ignore	ignore	$0.10 < \Phi \leq 0.25$	1	$\Phi > 0.30$	0	Minor
size(mm)	Acceptable number																												
	AA	Non-AA																											
$\Phi \leq 0.1$	ignore	ignore																											
$0.10 < \Phi \leq 0.25$	2																												
$0.25 < \Phi \leq 0.30$	1																												
$\Phi > 0.30$	0																												
size(mm)	Acceptable number																												
	AA	Non-AA																											
$\Phi \leq 0.1$	ignore	ignore																											
$0.10 < \Phi \leq 0.25$	1																												
$\Phi > 0.30$	0																												

		3.line(All inch LCD/touch panle)																																		
		<table border="1"> <thead> <tr> <th colspan="2">size(mm)</th> <th colspan="3">Acceptable number</th> </tr> <tr> <th rowspan="2">L(length)</th> <th rowspan="2">W(width)</th> <th colspan="3">area</th> </tr> <tr> <th>A</th> <th>B</th> <th>C</th> </tr> </thead> <tbody> <tr> <td>Ignore</td> <td>$W \leq 0.05$</td> <td colspan="3">Ignore</td> </tr> <tr> <td>$L \leq 3.0$</td> <td>$0.05 < W \leq 0.08$</td> <td colspan="3">3</td> </tr> <tr> <td>$L \leq 2.0$</td> <td>$0.08 < W \leq 0.1$</td> <td colspan="3">2</td> </tr> <tr> <td>-</td> <td>$W > 0.1$</td> <td colspan="3">Treat as dot</td> </tr> </tbody> </table>	size(mm)		Acceptable number			L(length)	W(width)	area			A	B	C	Ignore	$W \leq 0.05$	Ignore			$L \leq 3.0$	$0.05 < W \leq 0.08$	3			$L \leq 2.0$	$0.08 < W \leq 0.1$	2			-	$W > 0.1$	Treat as dot			
size(mm)		Acceptable number																																		
L(length)	W(width)	area																																		
		A	B	C																																
Ignore	$W \leq 0.05$	Ignore																																		
$L \leq 3.0$	$0.05 < W \leq 0.08$	3																																		
$L \leq 2.0$	$0.08 < W \leq 0.1$	2																																		
-	$W > 0.1$	Treat as dot																																		
4	Stain on LCD panel surface	Stain which cannot be removed even when wiped lightly with a soft cloth or similar cleaning too are rejected	Minor																																	
5	Rust in bezel	Rust which is visible with naked eyes in the bezel is rejected	Minor																																	
6	Cracking	Evident cracking which is visible are rejected	Minor																																	
7	Parts mounting	(1) failure to mount parts (2) parts not in the specification are mounted (3) polarizer, for example,is reversed	Major Major Major																																	
8	Parts alignment	(1) LSI,IC lead width is more than 50% beyond pad outline (2) Chip component is off center and more than 50% of the leads is off the pad outline	Minor Minor																																	
9	Conductive foreign matter	(1) on open space(gnd,manual solder)solder ball is allowed up to $\Phi \leq 0.1\text{mm}$ (1EA) (2) In case of shield space is allowed up to $\Phi 0.2\text{mm}$ (1EA)	Major																																	
10	Faculty PWB correction	(1) due to PWB copper foil pattern burnout,the patter is connected,using a jumper wire for repair;2 or more places corrected per PWB (2) short circuited part is cut,and no resist coating has been performed.	Minor Minor																																	

13. Suggestions For Using LCD Modules

13.1 Handling of LCM

13.1.1 The LCD screen is made of glass. Don't give excessive external shock, or drop from a high place.

13.1.2 If the LCD screen is damaged and the liquid crystal leaks out, do not lick and swallow.

When the liquid is attach to your hand, skin, cloth etc, wash it off by using soap and water thoroughly and immediately.

13.1.3 Do not apply excessive force to the display surface or the adjoining areas since this may cause the color tone to vary. Do not touch the display with bare hands. This will stain the display area and degraded insulation between terminals (some cosmetics are determined to the polarizer).

13.1.4 The polarizer covering the display surface of the LCD module is soft and easily scratched. Handle this polarizer carefully. Do not touch, push or rub the exposed polarizers with anything harder than an HB pencil lead (glass, tweezers, etc.). Do not put or attach anything on the display area to avoid leaving marks on it. Condensation on the surface and contact with terminals due to cold will damage, stain or dirty the polarizer. After products are tested at low temperature they must be warmed up in a container before coming in to contact with room temperature air.

13.1.5 If the display surface becomes contaminated, breathe on the surface and gently wipe it with a soft dry cloth.

If it is heavily contaminated, moisten cloth with one of the following solvents

- Isopropyl alcohol
- Ethyl alcohol

Do not scrub hard to avoid damaging the display surface.

13.1.6 Solvents other than those above-mentioned may damage the polarizer. Especially, do not use the following.

- Water
- Ketone
- Aromatic solvents

Wipe off saliva or water drops immediately, contact with water over a long period of time may cause deformation or color fading. Avoid contact with oil and fats.

13.1.7 Exercise care to minimize corrosion of the electrode. Corrosion of the electrodes is accelerated by water droplets, moisture condensation or a current flow in a high-humidity environment.

13.1.8 Install the LCD Module by using the mounting holes. When mounting the LCD module make sure it is free of twisting, warping and distortion. In particular, do not forcibly pull or bend the I/O cable or the backlight cable.

13.1.9 Do not attempt to disassemble or process the LCD module.

13.1.10 NC terminal should be open. Do not connect anything.

13.1.11 If the logic circuit power is off, do not apply the input signals.

13.1.12 Electro-Static Discharge Control , Since this module uses a CMOS LSI, the same careful attention should be paid to electrostatic discharge as for an ordinary CMOS IC. To prevent destruction of the elements by static electricity, be careful to maintain an optimum work environment.

- Before removing LCM from its packing case or incorporating it into a set, be sure the module and your body have the same electric potential. Be sure to ground the body when handling the LCD modules.
- Tools required for assembling, such as soldering irons, must be properly grounded. Make certain the AC power source for the soldering iron does not leak. When using an electric screwdriver to attach LCM, the screwdriver should be of ground potentiality to minimize as much as possible any transmission of electromagnetic waves produced sparks coming from the commutator of the motor.